

RC4WD TRAIL FINDER 2 RTR W/CHEVROLET BLAZER BODY SET (MIDNIGHT EDITION)



OFFICIAL LICENSED PRODUCT

TRAIL FINDER 2 BLAZER MIDNIGHT EDITION

RC4WD TRAIL FINDER 2 RTR W/CHEVROLET BLAZER BODY SET (MIDNIGHT EDITION)

FEATURES

1. CHEVROLET BLAZER HARD BODY COMPLETE SET (BLACK)
2. CHEVROLET BLAZER AND K10 CHROME GRILLE (BLACK)
3. SMALL BLOCK V8 ENGINE BAY W/DRESS UP KIT
4. RALLY 1.9" BEADLOCK WHEELS (BLACK)
5. DICK CEPEK 1.9" MUD COUNTRY SCALE TIRES
6. K44 ULTIMATE SCALE CAST AXLES (XVD)
7. THE ULTIMATE SCALE SHOCKS (80MM) (CHROME)
8. SUPER SOFT FLEX LEAF SPRINGS FOR TRAIL FINDER 2
9. 540 CRAWLER BRUSH MOTOR 45T
10. R3 SINGLE SPEED TRANSMISSION
11. CENTER MOUNTED HAMMER TRANSFER CASE
12. TWISTER HIGH TORQUE METAL GEAR DIGITAL SERVO
13. OUTCRY III WATERPROOF ESC
14. 6-CELL 3000MAH NIMH BATTERY W/ XT60 PLUG
15. MARLIN CRAWLER SIDE PLASTIC SLIDERS FOR TRAIL FINDER 2
16. FRONT INNER FENDER SET FOR CHEVROLET BLAZER AND K10 (BLACK)
17. XR3 3-CHANNEL 2.4GHZ TRANSMITTER/RECEIVER RADIO
18. UNIVERSAL NIMH PEAK BATTERY CHARGER

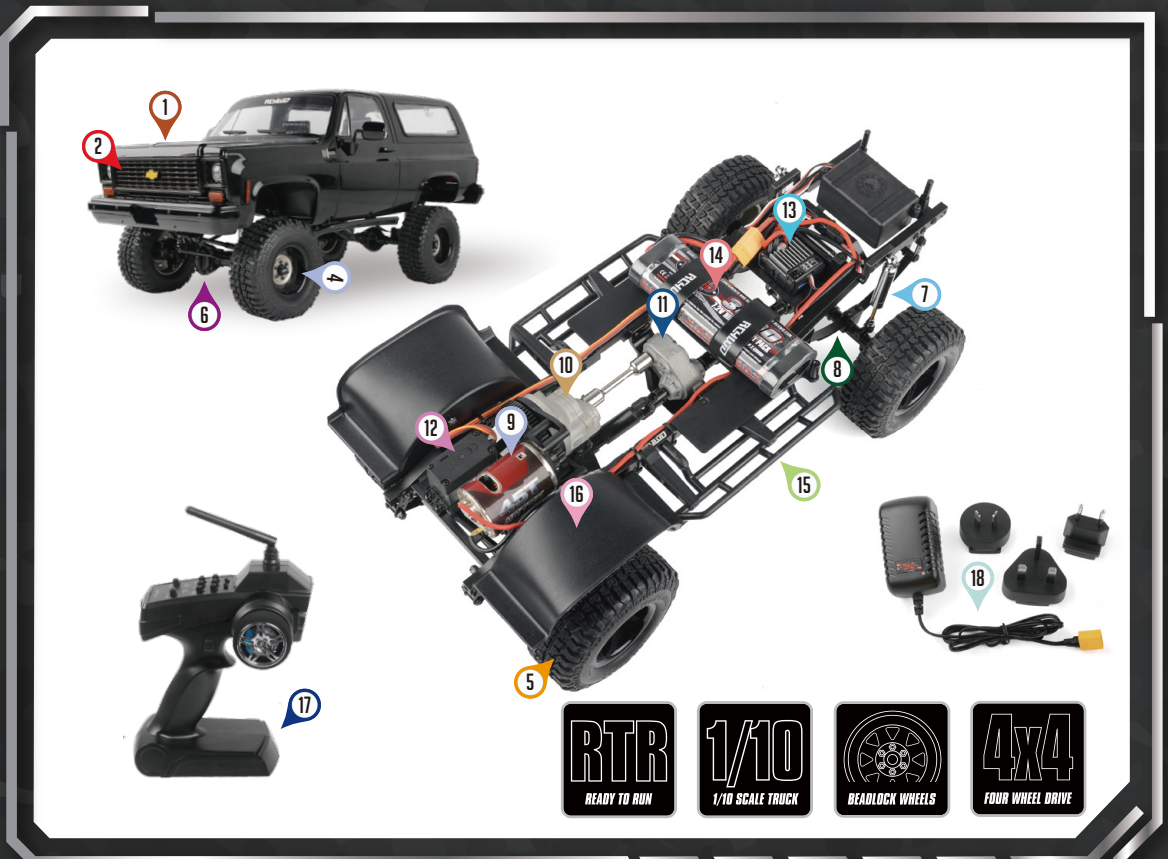
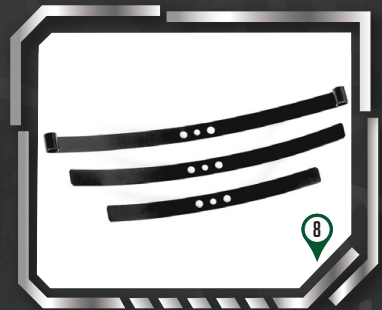
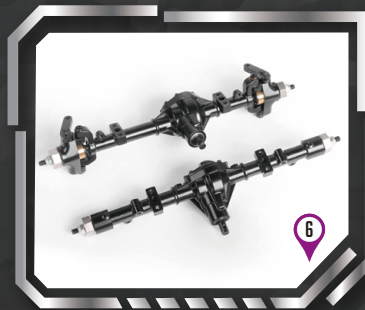

ULTIMATE SCALE IS BACK, IN BLACK, WITH THE SLEEK RC4WD TRAIL FINDER 2 RTR W/CHEVROLET BLAZER BODY SET (MIDNIGHT EDITION)!

THIS RTR BRINGS AN ALL-BLACK-EVERYWHERE APPROACH, WITH THE CHROME FINISH FROM THE TRIM AND ACCESSORIES BLACKED OUT, GIVING THE CHEVROLET BLAZER A DARK AND CLASSY APPEARANCE. THE TOPPER HAS A MATTE FINISH, CONTRASTING THE GLOSS BLACK PAINT JOB OF THE BLAZER BODY! UNDERNEATH THE OPENING HOOD, THE ENGINE BAY HAS A DRESS-UP KIT, MOLDED PARTS, AND PAINTED PARTS LIKE THE VALVE COVERS!

THIS MODEL COMES MOUNTED TO THE POPULAR TRAIL FINDER 2 CHASSIS WITH NEW AND FIELD-TESTED IMPROVEMENTS! TRAIL-READY SUSPENSION PARTS COME TUNED OUT OF THE BOX, WITH THE INTERNAL SHOCK SPRINGS AND HELPER LEAF SPRINGS UNINSTALLED, THOUGH INCLUDED AND AVAILABLE FOR PERSONAL TUNING! THE NEW REAR SHOCK TOWERS ALLOW FOR LONGER SHOCKS AND ADJUSTABLE MOUNTING POSITIONS, ADDING TO THE CUSTOMIZATION! THE CUSTOM-PAINTED RALLY WHEELS COME WRAPPED IN DICK CEPEK TIRES, READY TO HIT THE TRAIL IN STYLE!

OWN THIS MODEL AND EXPERIENCE THIS MODERN TAKE ON AN AMERICAN CLASSIC TODAY!

RTR
READY TO RUN

1/10
SCALE TRUCK

BEADLOCK WHEELS

4x4
FOUR WHEEL DRIVE

RC4WD

TRAIL FINDER 2

BLAZER

MIDNIGHT EDITION

DRIVE TRAIN

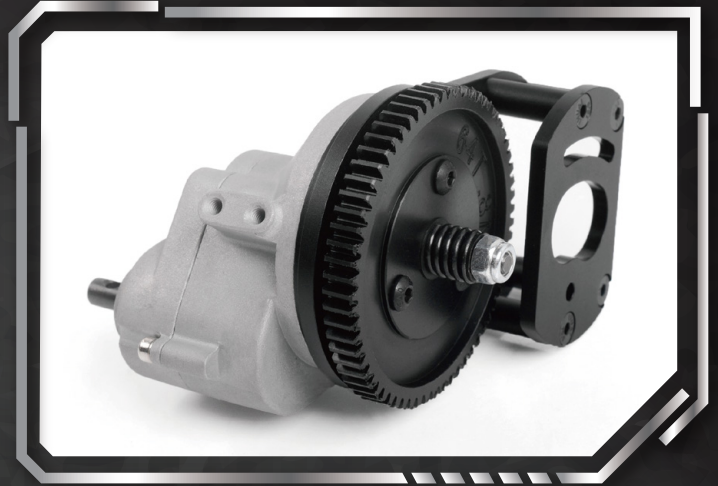

The R3 Single Speed Transmission comes with a tough cast metal case and wider gears for durability and a Delrin Spur with Slipper Clutch for performance. It also features a sturdy billet aluminum motor mount for added toughness.

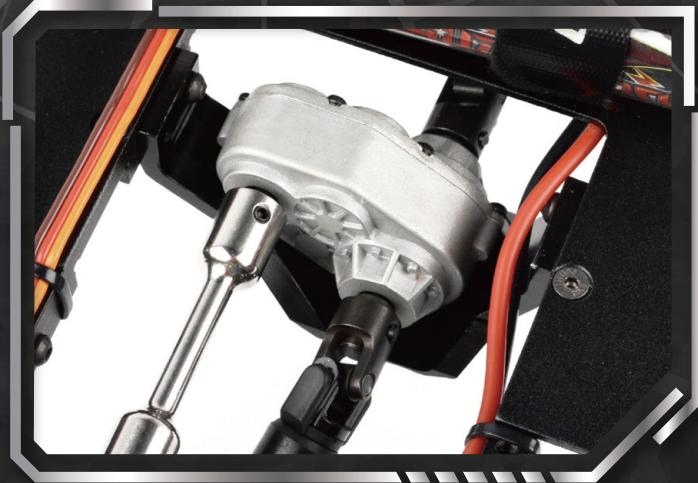

The Trail Finder 2 Chassis includes the Hammer Transfer Case that features a cast metal exterior and heavy-duty .8 Mod Widened Gears, ensuring lasting functionality.



Drawing on the success of the RC4WD MOA Gear Sets, the Trail Finder 2 Chassis has the most durable gears RC4WD has to offer, capable of staying on the trail day after day.



The most scale-accurate axles on the market, the K44 Ultimate Scale Cast Axles feature high steer knuckles, XVDs, lower mounting points, and a compact offset front pumpkin.



The driveshafts found on the Trail Finder 2 Chassis feature heavy-duty uni-joint metal shafts for great driveline angles and durability on the trail.

PRECISION ENGINEERED · BULLET-PROOF COMPONENTS · PERFORMANCE PARTS

For more information, upgrades and all the latest news, visit us at: rc4wd.com

RC4WD

TRAIL FINDER 2

BLAZER

MIDNIGHT EDITION

PRECISION
ENGINEERED
BULLET-PROOF
COMPONENTS
PERFORMANCE
PARTS



The Trail Finder 2 Chassis has a multi-purpose, molded fuel cell that serves as an electronics storage box and provides additional RC realism by storing away any protruding wires.



The Trail Finder 2 Chassis includes Ultimate Scale Shocks 80mm (Chrome) with Internal Springs. These ultimate scale shock absorbers offer realistic looks and performance. They are machined from billet aluminum with internal springs and rebuildable internal parts!

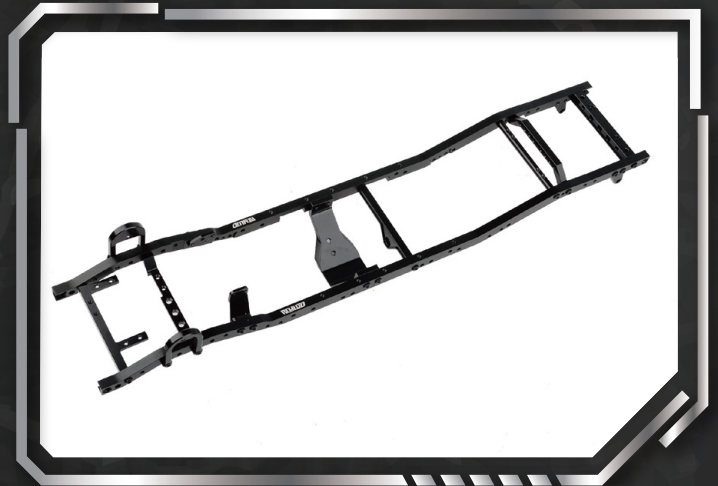

With strength in mind, the ladder frame design of the Trail Finder 2 Chassis is made with CNC machined, billet aluminum and comes with scale shock hoops, a chassis servo mount, and transmission and transfer case mounts.



This truck includes a set of Rally 1.9" Beadlock Wheels (Black). The wheels are stamped steel and have a smooth black finish with a black finish beauty ring for extra detail.



Every RTR needs a tough set of tires to hit the trails and the included Dick Cepek 1.9" Mud Country Scale Tires deliver the perfect amount of traction with its advanced X3 soft and sticky compound. The scale details complete the look in just the right size.

PRECISION ENGINEERED · BULLET-PROOF COMPONENTS · PERFORMANCE PARTS

For more information, upgrades and all the latest news, visit us at: rc4wd.com

RC4WD

TRAIL FINDER 2

BLAZER

MIDNIGHT EDITION

PRECISION ENGINEERED



The Trail Finder 2 Chassis is powered by the tough and durable RC4WD 45 Turn Crawler Motor. With long-lasting performance at its core, this power machine is tuned for rock climbing and scale driving!

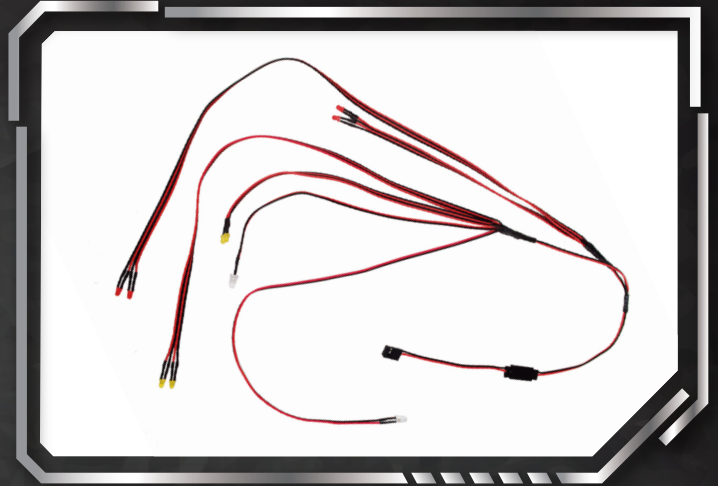

Straight out of the box, an LED light set comes professionally installed and out of sight, keeping that realistic look.

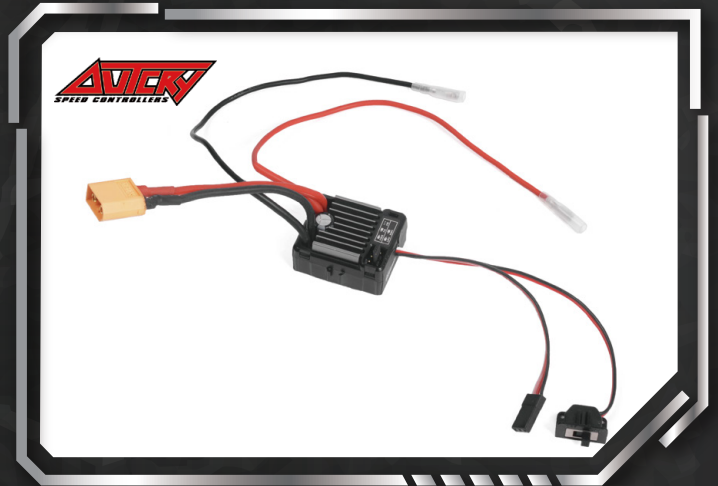

Included is the popular RC4WD Outcry III Waterproof ESC Brushed Speed Controller, with built-in drag brake, for reliable constant power on demand at any time!



With a massive 277.6oz@6V of torque and a full metal geared drivetrain, the RC4WD Twister Metal Gear Digital Servo has the power and performance needed to outmaneuver and overcome tough terrain.



It's ALL in the box! Everything you need is provided to get you on the trails today!

PRECISION ENGINEERED · BULLET-PROOF COMPONENTS · PERFORMANCE PARTS

For more information, upgrades and all the latest news, visit us at: rc4wd.com

RC4WD

TRAIL FINDER 2

BLAZER

MIDNIGHT EDITION



This RTR comes with a unique, custom-painted Chevrolet Blazer Hard Body that features an assortment of scale details including mirrors, door handles, and interchangeable grille options!



The body is constructed of durable hard plastic with a classic shape that replicates the full-size model with accuracy and authenticity.



With realism in mind, the body features a molded, realistic drop bed and an opening hood and tailgate. The masters of scale continue to deliver unmatched details!



This model includes a removable matte topper that contrasts the glossy look of the body! Install or uninstall it for a style switch and hit the look of an open or enclosed Blazer!



Included are black finish parts and colored lenses for all signal lights! Typical chrome trimming now comes blacked out, adding to the eye-catching dark aesthetics of this RTR!

GO ALL THE WAY TO THE FINISH

PRECISION ENGINEERED · BULLET-PROOF COMPONENTS · PERFORMANCE PARTS

For more information, upgrades and all the latest news, visit us at: rc4wd.com

RC4WD

TRAIL FINDER 2

BLAZER

MIDNIGHT EDITION



PRECISION
ENGINEERING

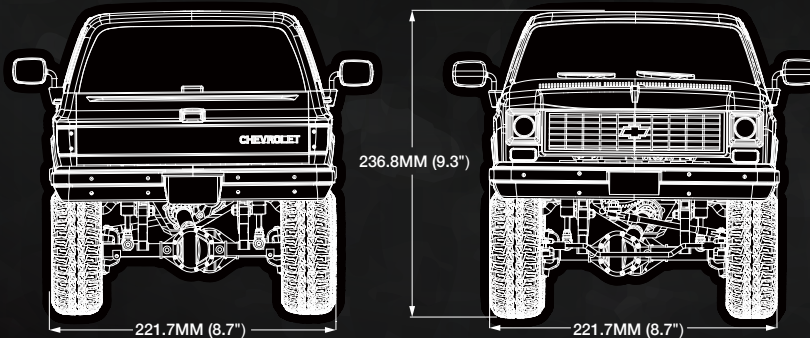
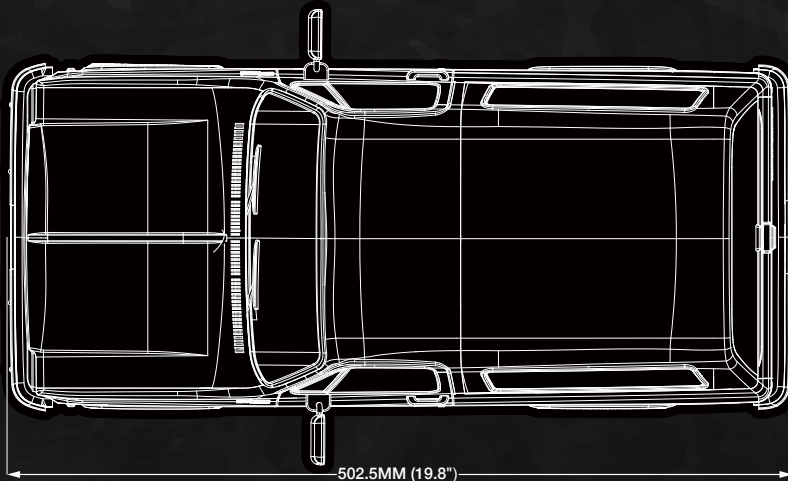
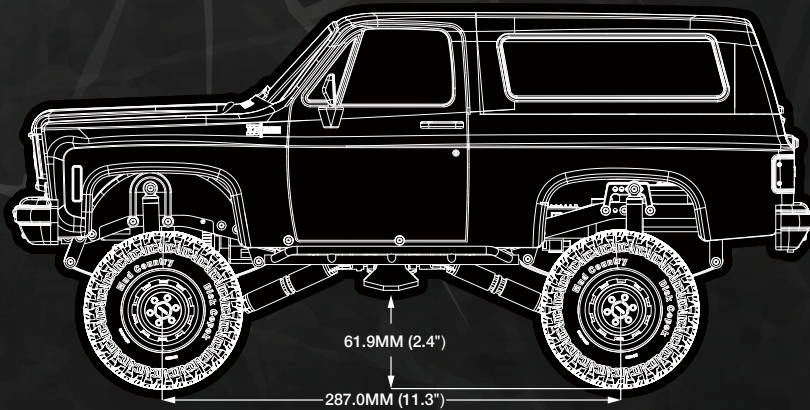

MORE INFO

Hammer Transfer Case

Ratio: 1.47:1

Gears: Wide .8 Mod Hardened Steel Gears

Features: 8 Bearings, Cast Casing, Hardened Gears

R3 Scale Single Speed Transmission

Ratios: Pinion/Spur 14/64 = 1:4.57

Internal Ratio: 1.78:1

Gears: Wide Steel .8 Mod, Delrin Spur,

Slipper Clutch

K44 Ultimate Scale Cast Axles

Ratio: 2.67:1

Hex To Hex Width: 177mm (6.96")

Shock Absorbers

The Ultimate Scale Shocks (80mm) (Chrome)

Titanium Nitrate Coated Shock Shafts

New X-Ring Technology

Wheels

Type: Rally 1.9" Beadlock Wheels (Black)

Hub: 12mm Hex

Width: 33mm (1.29")

OD: 54mm (2.14")

Tires

Type: RC4WD Dick Cepek 1.9" Mud Country

Scale Tires

Outer Diameter: 100mm (3.95")

Width: 38.9mm (1.53")

Inner Diameter: 48mm (1.9")

Trail Finder 2 Truck Dimensions

Wheelbase: 287mm (11.3")

Width: 221.7mm (8.7")

Height: 236.8mm (9.3")

Ground Clearance: 61.9mm (2.4")

Final Drive Ratio: 31.9:1

PRECISION ENGINEERED · BULLET-PROOF COMPONENTS · PERFORMANCE PARTS

For more information, upgrades and all the latest news, visit us at: rc4wd.com