

RC4WD TRAIL FINDER 2 RTR W/1985 TOYOTA 4RUNNER HARD BODY SET (RED)



TOYOTA

OFFICIAL
LICENSED
PRODUCT

TRAIL FINDER 2 4Runner

RC4WD TRAIL FINDER 2 RTR W/ 1985 TOYOTA 4RUNNER HARD BODY SET (RED)

FEATURES

- 1 1/10 1985 TOYOTA 4RUNNER HARD BODY COMPLETE SET IN RED
- 2 PRE-PAINTED WHITE TOPPER
- 3 PRE-INSTALLED LED LIGHT SET
- 4 FULLY DETAILED YOTA 22RE ENGINE BAY
- 5 STAMPED STEEL 1.7" BEADLOCK SR5 WHEELS (CHROME)
- 6 RC4WD MILESTAR PATAGONIA M/T 1.7" SCALE TIRES
- 7 YOTA II ULTIMATE SCALE CAST AXLES (XVD)
- 8 RC4WD ULTIMATE SCALE SHOCKS
- 9 SOFT STEEL LEAF SPRINGS
- 10 540 CRAWLER BRUSH MOTOR 45T
- 11 R3 SINGLE SPEED TRANSMISSION
- 12 CENTER MOUNTED HAMMER TRANSFER CASE
- 13 TWISTER HIGH TORQUE METAL GEAR DIGITAL SERVO
- 14 OUTCRY III WATERPROOF ESC
- 15 6-CELL 3000MAH NIMH BATTERY W/XT60 PLUG
- 16 RC4WD MARLIN CRAWLER SIDE PLASTIC SLIDERS
- 17 FRONT & REAR INNER FENDER SET
- 18 XR3 3-CHANNEL 2.4GHZ TRANSMITTER/RECEIVER RADIO
- 19 UNIVERSAL NIMH PEAK BATTERY CHARGER
- 20 UNINSTALLED PLASTIC FRONT WINCH BUMPER

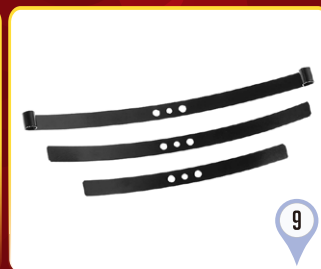

NOW FEATURING XVD AXLE SHAFTS



ADVENTURES CAN HAPPEN ANYWHERE. NOTHING WILL GIVE YOU MORE FUN IN THE SAND, DIRT, SNOW OR MUD THAN THE TRAIL FINDER 2. PART SCALE TRUCK, PART ADVENTURER, YOUR TRAIL FINDER 2 IS READY FOR YOUR MUD KICKING, TRAIL-LOVING LIFESTYLE!

THE TRAIL FINDER 2 HAS BOTH DETAILED STYLING AND AGGRESSIVE PERFORMANCE. YOU WILL FIND A BALANCE OF CAPABILITY AND PERFORMANCE BUILT INTO EVERY TRAIL FINDER 2. PERFORMANCE OF THE TRAIL FINDER 2 IS SMOOTH WITH ITS R3 SINGLE SPEED TRANSMISSION, 4WD DRIVETRAIN, BULLETPROOF TRANSFER CASE AND QUALITY METAL COMPONENTS THROUGHOUT. THE TRAIL FINDER 2 IS TRULY A WORK OF ART IN BOTH APPEARANCE AND PERFORMANCE.

EVERY TRAIL FINDER 2 IS COMPATIBLE WITH A FULL RANGE OF OPTIONS AND PERFORMANCE PARTS DESIGNED TO ENHANCE THE PERFORMANCE AND ADD TO THE SCALE LOOK OF THE TRUE SCALE 1/10 OFF-ROAD TRUCK... THE TRAIL FINDER 2!

YOUR ADVENTURE AWAITS!

RTR
READY TO RUN

1/10
1/10 SCALE TRUCK

BEADLOCK WHEELS

4x4
FOUR WHEEL DRIVE

RC4WD TRAIL FINDER 2 RTR W/1985 TOYOTA 4RUNNER HARD BODY SET (RED)

RC4WD

TRAIL FINDER 2

4Runner

DRIVETRAIN



The R3 Single Speed Transmission comes with a tough cast metal case and wider gears to allow for more abuse along with a Delrin Spur with Slipper Clutch. It also features a sturdy billet aluminum motor mount for durability.



The 4Runner RTR includes the Hammer Transfer Case. Packed with detail, the Hammer features a cast metal exterior and heavy duty .8 Mod widened gears for durability.



Drawing on the success of the RC4WD MOA gear sets, the TF2 RTR Drivetrain has the most durable gears RC4WD has to offer so the 4Runner RTR will stay on the trail, day after day.



The most scale accurate axles on the market, the RC4WD Yota II Ultimate Scale Cast Axles feature innovative 8 degree round knuckles, unique removable diff covers, lower mounting points and a compact offset pumpkin in the front.



The Punisher Shafts for the TF2 feature bulletproof steel universals and a high quality plastic shaft for great driveline angles and durability on the trail.

PRECISION ENGINEERED · BULLET-PROOF COMPONENTS · PERFORMANCE PARTS

For more information, upgrades and all the latest news, visit us at: rc4wd.com

RC4WD TRAIL FINDER 2 4Runner



The 4Runner RTR Chassis features a molded fuel cell that doubles as an electronics storage box plus an aluminum frame mounted under cab electronics tray for multiple electronics mounting options.



The 4Runner RTR includes a set of RC4WD Ultimate Scale Shocks. Designed with scale looks and ultimate performance. The shocks are machined from billet aluminum and internally sprung.



The 4Runner RTR Chassis is a machined billet aluminum ladder frame design with leaf springs, scale shock hoops, chassis servo mounts and hard body mounts. 4-link conversion available!



The 4Runner RTR includes a set of Stamped Steel 1.7" Beadlock SR5 Wheels (Chrome). These are a stamped steel construction with a clear coat finish.



Every off-road truck needs a tough set of tires, and the 4Runner RTR comes equipped with RC4WD Milestar Patagonia M/T 1.7" Scale Tires compound to deliver the traction needed to get you through the roughest terrain.

PRECISION ENGINEERED • BULLET-PROOF COMPONENTS • PERFORMANCE PARTS

For more information, upgrades and all the latest news, visit us at: rc4wd.com

SUSPENSION

RC4WD TRAIL FINDER 2 4Runner

ELECTRONICS



The 4Runner RTR includes a quality XR3 3 channel 2.4Ghz radio system. Use the third channel to control a winch and add even more fun to your scale adventure!



The 4Runner RTR is powered by the nearly indestructible RC4WD 45 Turn Crawler Motor. With its sealed endbell for increased durability and long lasting performance, you're sure to get where you're going.

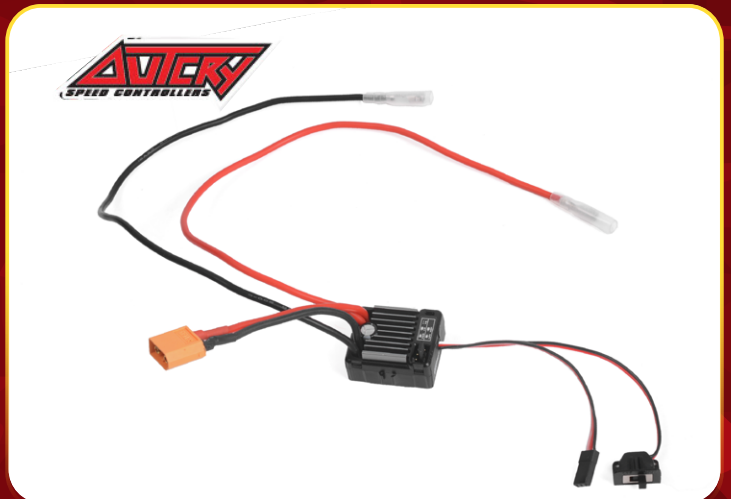

The 4Runner RTR features the popular RC4WD Outcry III Waterproof ESC Brushed Speed Controller with built-in drag brake for reliable, constant power on demand. Anytime.



A great truck needs a great servo to get you out of those tough spots and the 4Runner RTR features the Twister. A high torque metal gear digital servo to handle all your steering duties.



Featuring a massive 277.6oz@6V of torque and a full metal geared drivetrain, the RC4WD Twister Metal Gear Digital Servo has the power and performance you need when the turning gets tough.

PRECISION ENGINEERED • BULLET-PROOF COMPONENTS • PERFORMANCE PARTS

For more information, upgrades and all the latest news, visit us at: rc4wd.com

RC4WD TRAIL FINDER 2 4Runner



The 4Runner RTR has an awesome assortment of scale details including mirrors, door handles, vents and a grill to match the 1:1 real vehicle.



The 4Runner Body Set features a plethora of scale characteristics including opening doors, a removable top, and an ultra detailed Yota 22RE Engine Bay.



Comprised of over 20 parts, the 4Runner Body interior comes in durable, molded hard plastic that is professionally painted to match a full scale vehicle. The vents, steering wheel, shift knobs and door handles are all present to show the realism.



The 4Runner has a complete molded plastic engine bay that comes painted with decals installed for an extremely scale appearance.



The interior of the 4Runner is complete with LED light buckets, and an operational tailgate. The interior is painted to match the exterior.

THE DETAILS

PRECISION ENGINEERED • BULLET-PROOF COMPONENTS • PERFORMANCE PARTS

For more information, upgrades and all the latest news, visit us at: rc4wd.com

RC4WD

TRAIL FINDER 2 4Runner



SPECIFICATIONS

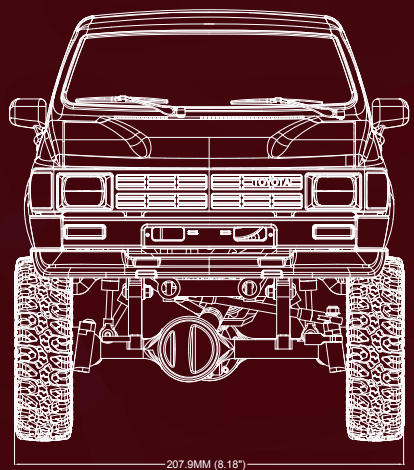
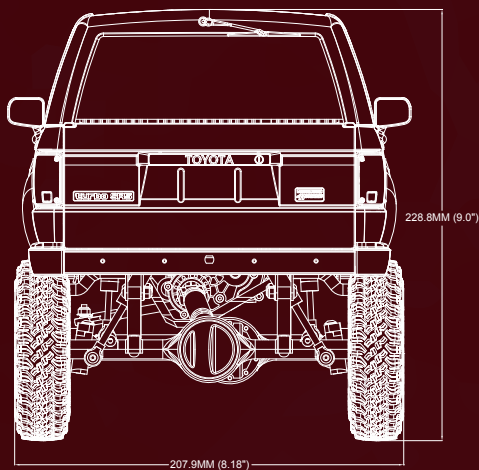
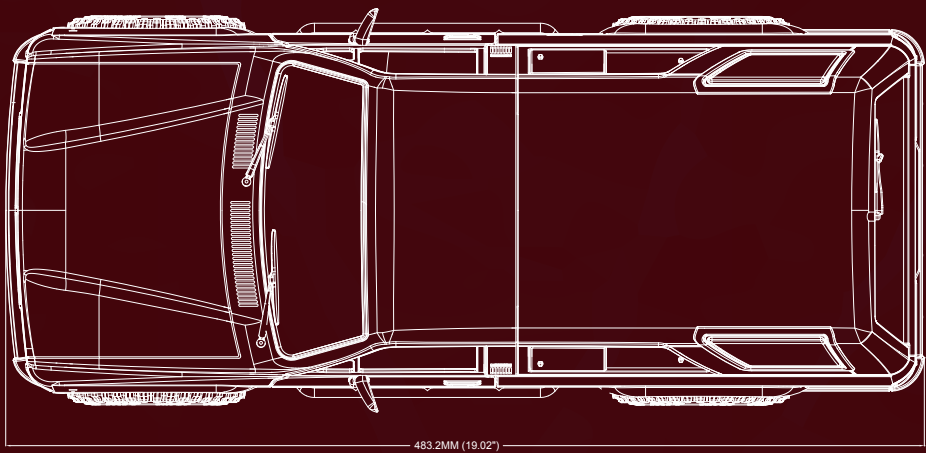
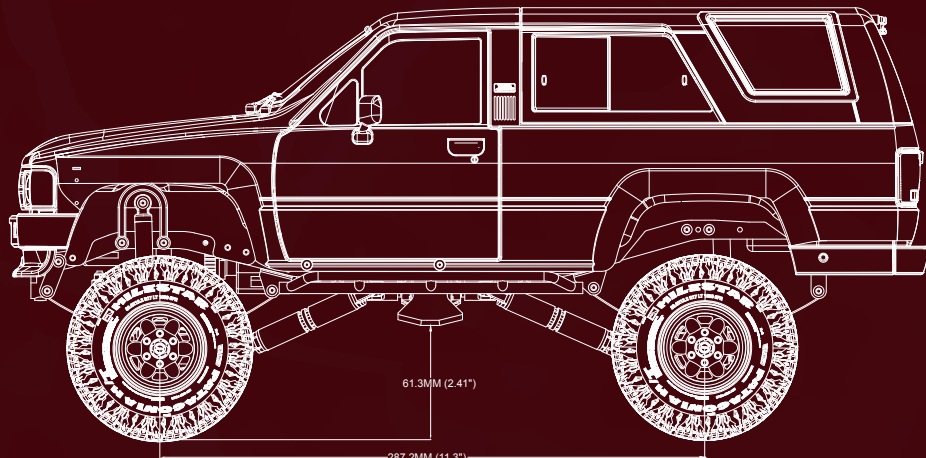

MORE INFO

Hammer Transfer Case

Ratio: 1.47: 1 Gears: Wide .8 Mod Steel Gears
Features: 8 Bearings, Cast Casing, Hardened Gears

R3 Single Speed Transmission

Ratios: Pinion/Spur 14/64 = 4.57:1 Internal Ratio = 1.78:1
Gears: Wide Steel .8 Mod, Delrin Spur, Slipper Clutch, Features - Metal Billet Aluminum Casing, Scale Looking, Motor Mount can be Rotated to 10 different Positions, Compatible with other Brand Spurs (Axial, Traxxas, Robinson)

Yota II Ultimate Scale Cast Axles

Ratio: 15/40 = 2.67:1
Width at Hex: 178.2mm

Trail Finder 2 Chassis Features

Features: Billet Aluminum Construction, Adjustable Shock Hoops

Drive Shafts

RC4WD Plastic Punisher Shaft V2 (102mm-110mm / 4.02" - 4.33") 5mm Hole

Wheels

Type: Stamped Steel 1.7" Beadlock SR5 Wheels (Chrome) Hub: 12mm Hex Width: 23.0mm (0.90") OD: 47.0mm (1.85")

Bumpers

Marlin Crawler Front Plastic Tube Bumper
Marlin Crawler Side Plastic Sliders
Authentic crawler-style bumper, high quality flexible plastic, extremely durable and ultra scale

TF2 Truck Dimensions

Wheelbase: 287.2mm (11.3")
Width: 207.9mm (8.18")
Height: 228.8mm (9.0")
Ground Clearance: 61.3mm (2.41")
Final Drive Ratio: 31.93:1

PRECISION ENGINEERED · BULLET-PROOF COMPONENTS · PERFORMANCE PARTS

For more information, upgrades and all the latest news, visit us at: rc4wd.com