

# JDM-155 1/14 Overland 4x4 ARTR RC Truck

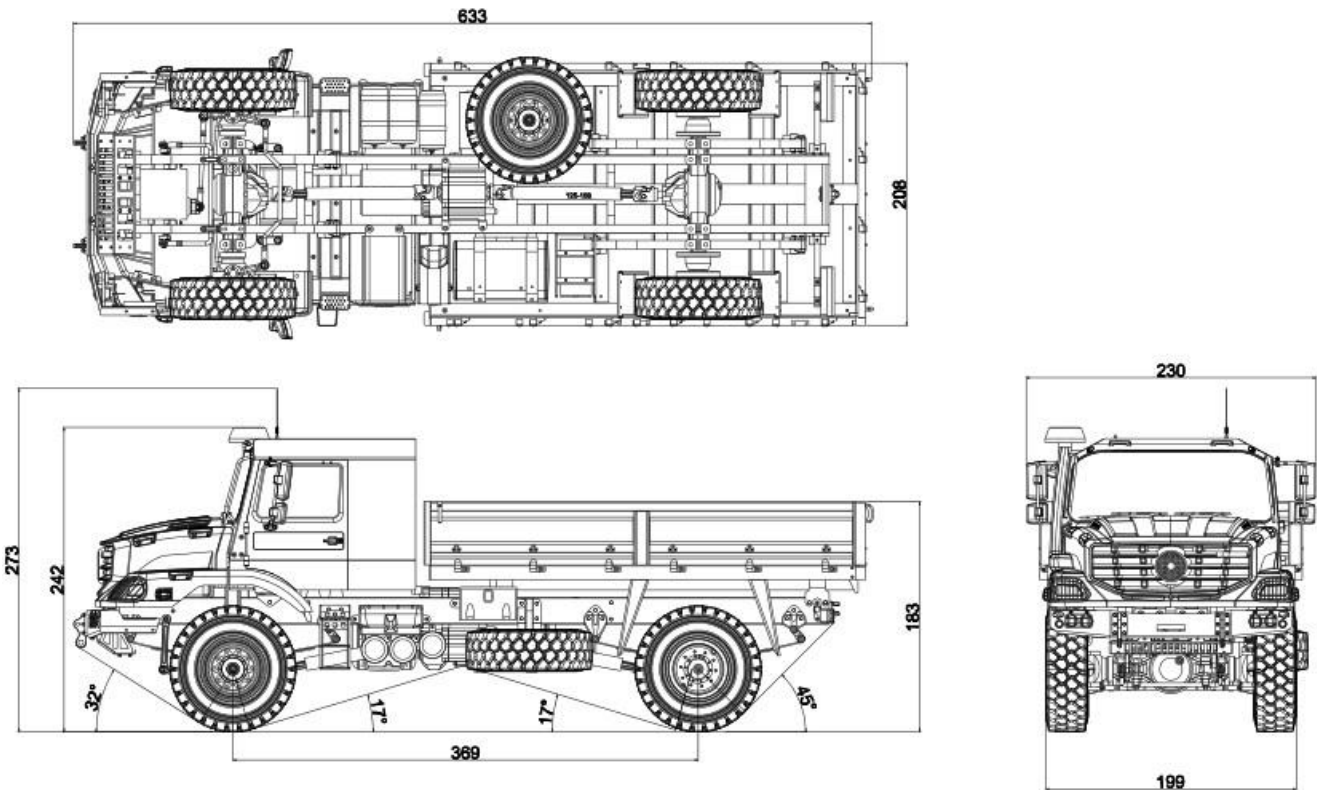



Scale: 1:14

Dimensions: length 633, width 230, height 273 (excluding antenna 233), unit: mm

Wheelbase: total wheelbase 369mm

Front shock absorber stroke: 20 mm

Battery Specification: 3S, 5200mAh, 11.1v, above 25C; battery compartment size: 142 \* 45 \* 40MM (battery size is within this range)

battery needs to be purchased separately

Weight: 3.3kg

Theoretical load: 8kg

Total weight: 12kg

Controller needs to be purchased separately

## Remove the cab

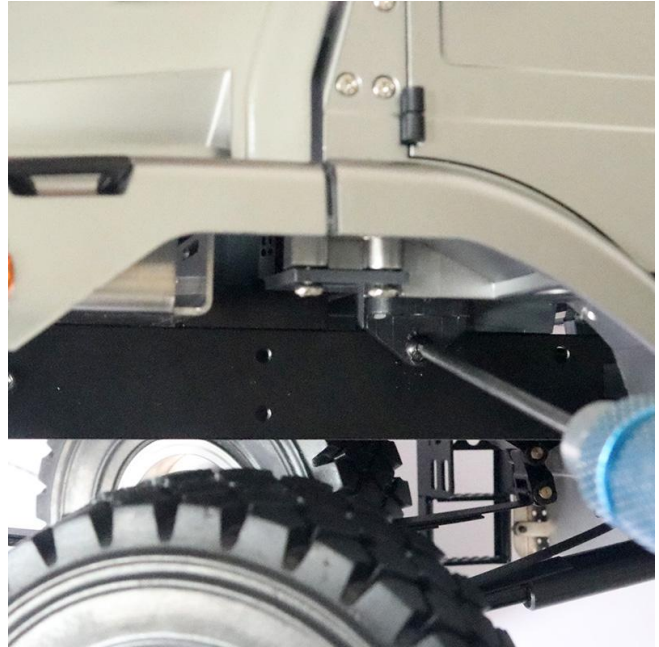
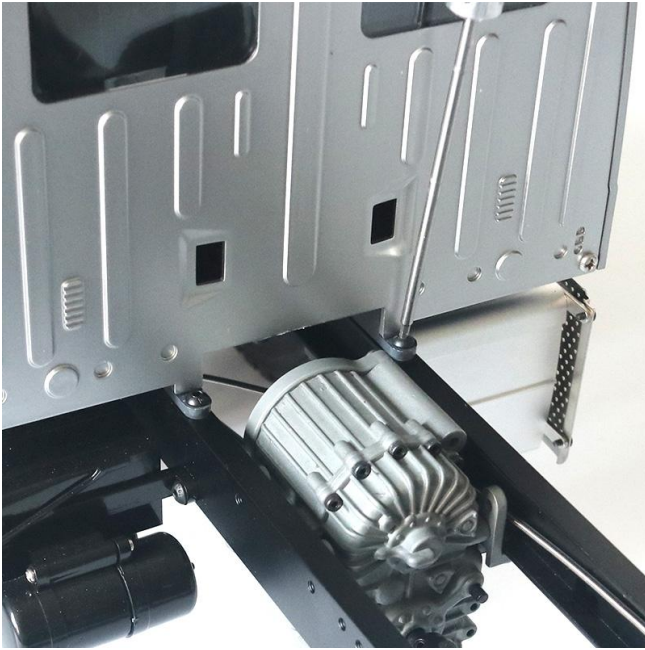

## Remove the hood



Remove the hood



Remove the battery box

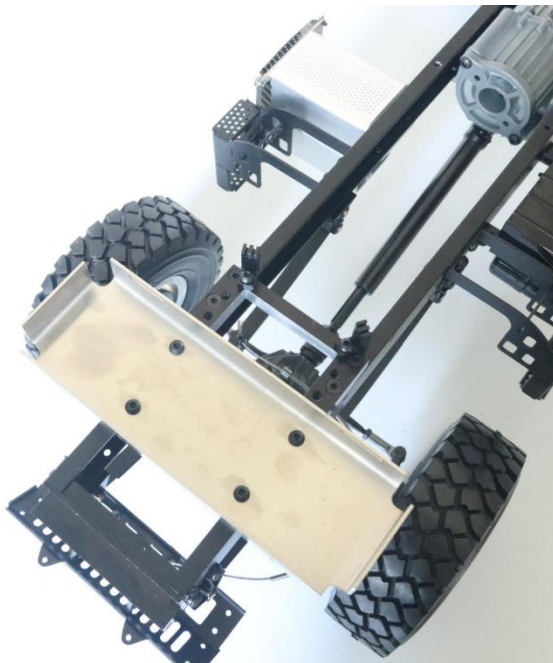

Remove the holder and the cable mount piece



Install the steering gear  
(the steering gear needs to  
be purchased separately)

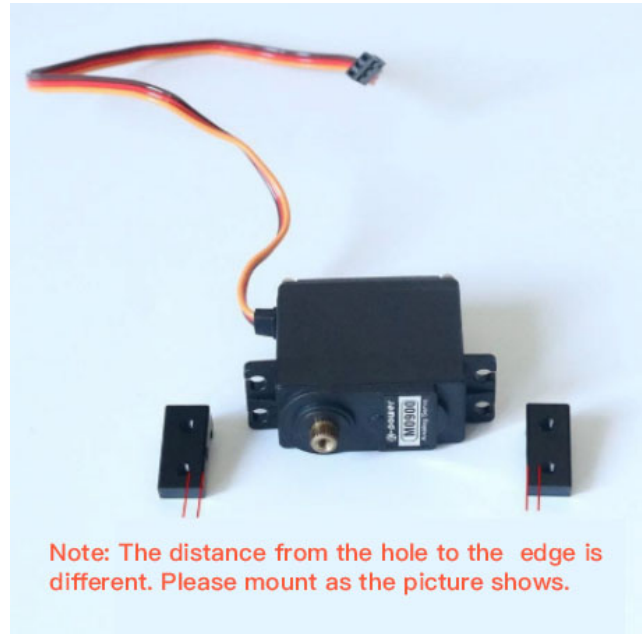

Note: The distance from the hole to the edge is different. Please mount as the picture shows.



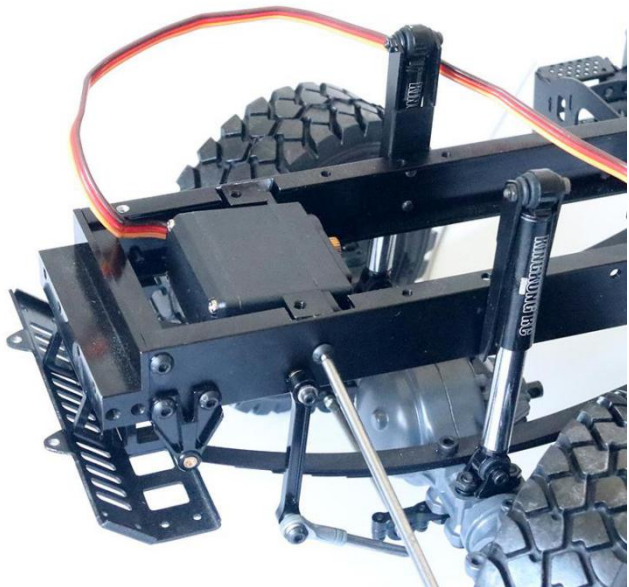
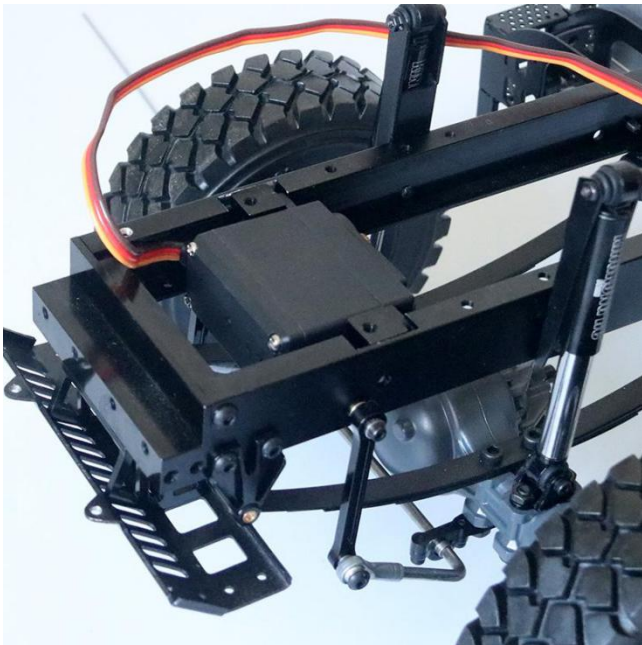
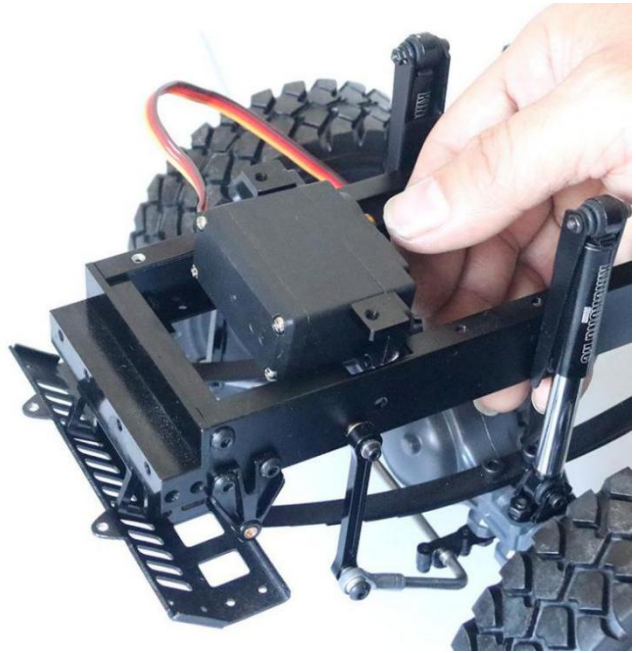

Use BHCS M3\*8mm

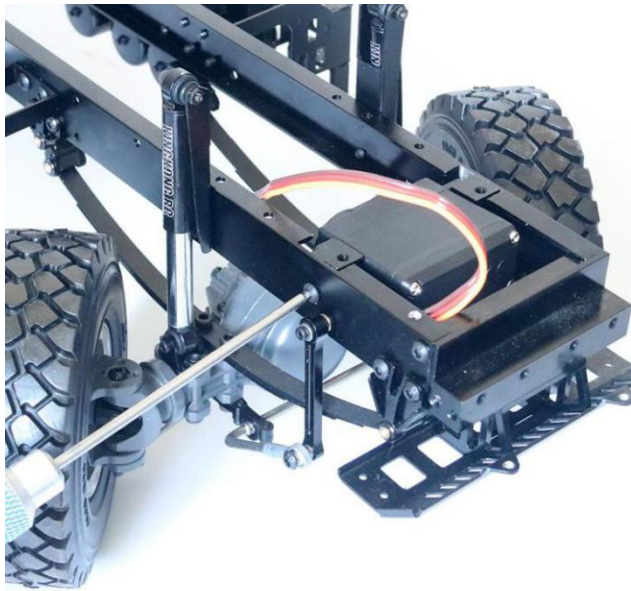

Use BHCS M3\*8mm



Install the transmission shift servo gear (the servo gear needs to be purchased separately)



Assemble the cable mount  
and install 2pc of BHCS M3  
\* 8mm

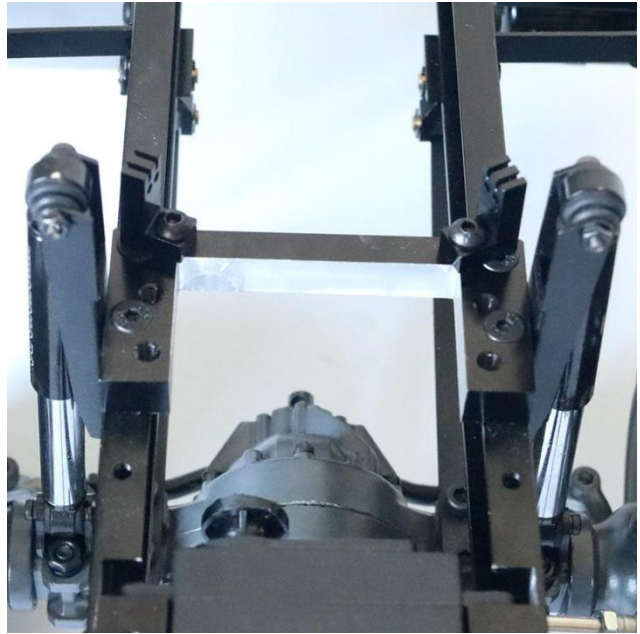
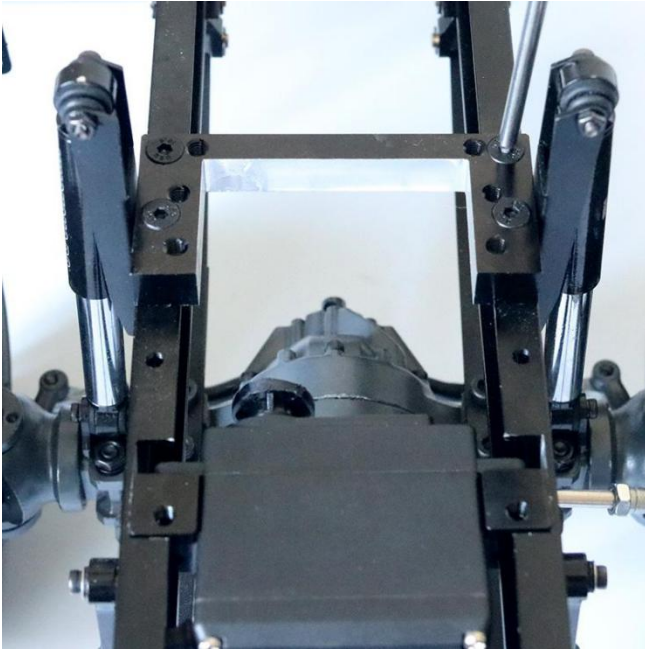

(Install 4pc FHCS M3 \* 8mm)

Remove the gearbox

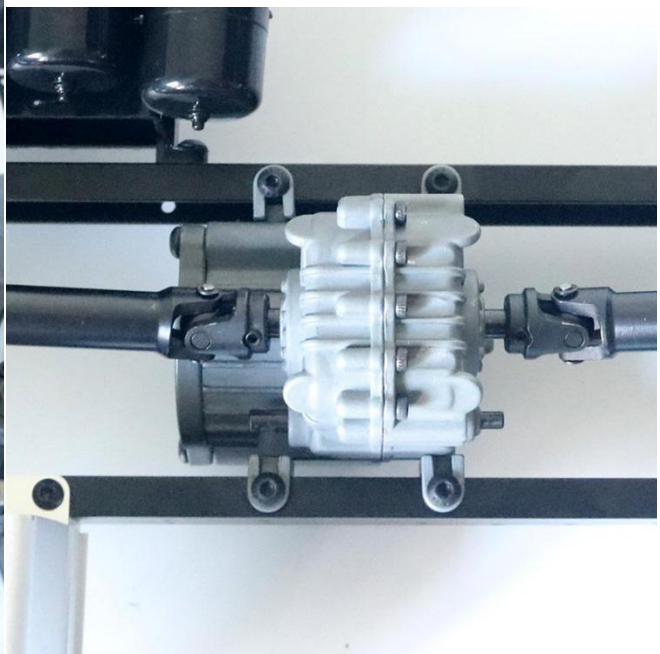
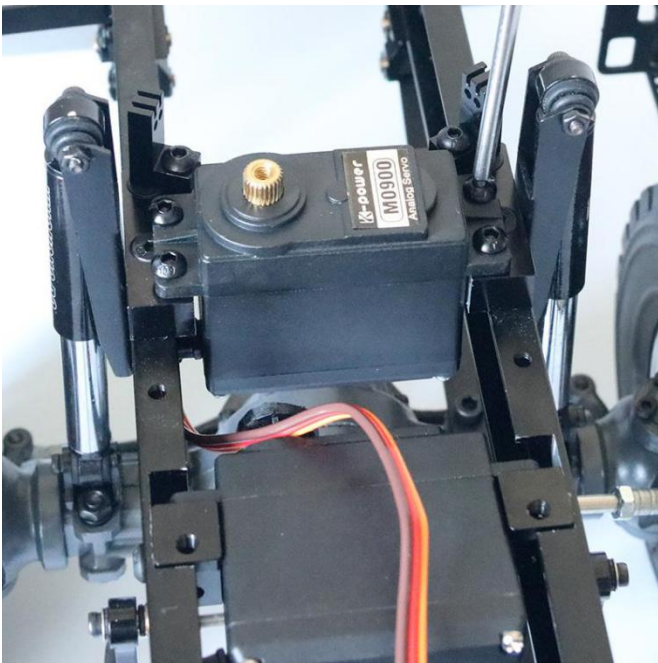

Install the gearbox (the motor needs to be purchased separately)

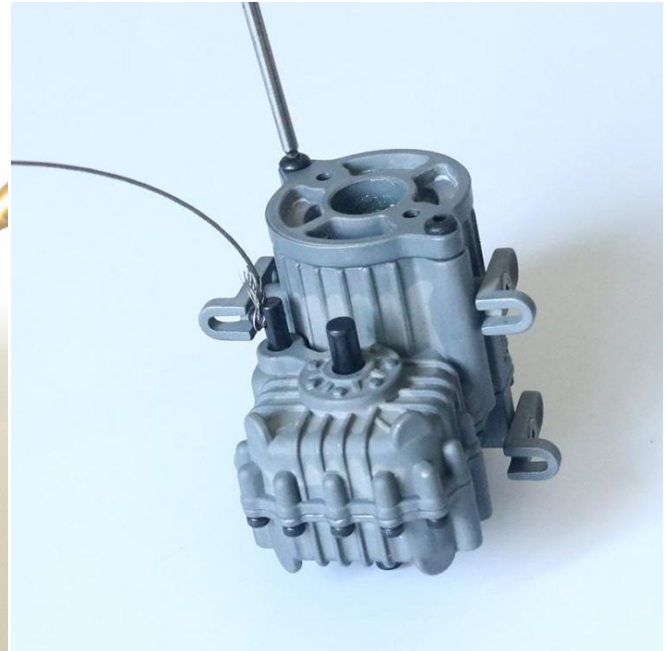
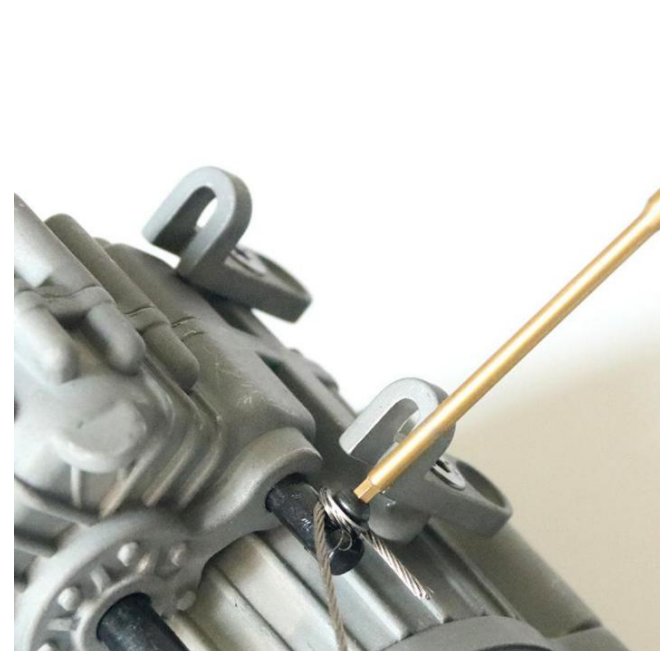
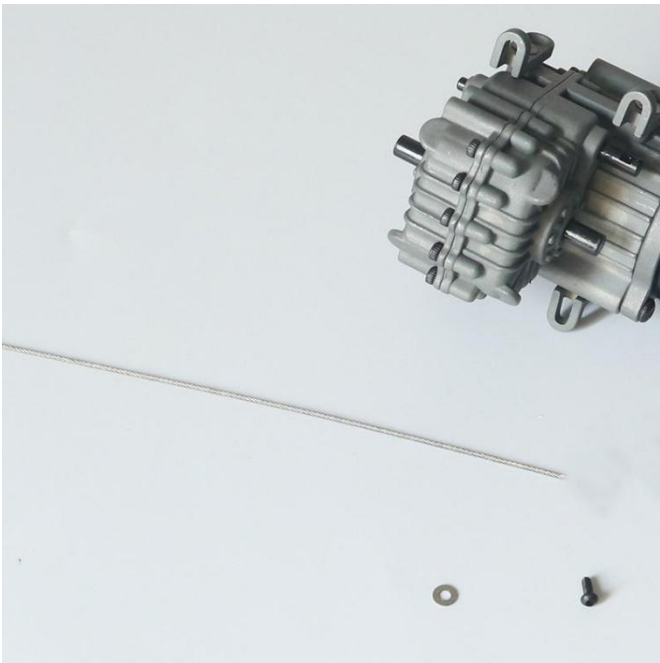

The motor needs to be purchased separately. It is recommended to use 35T, 2pc of SHCS m3 \* 6mm.

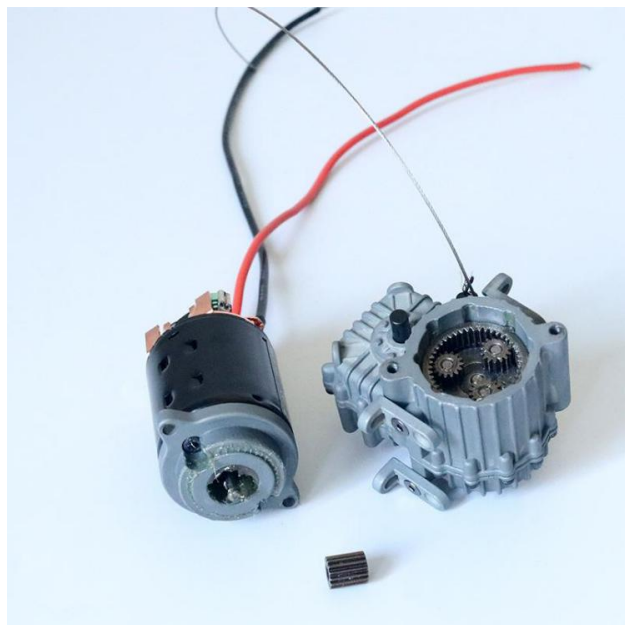
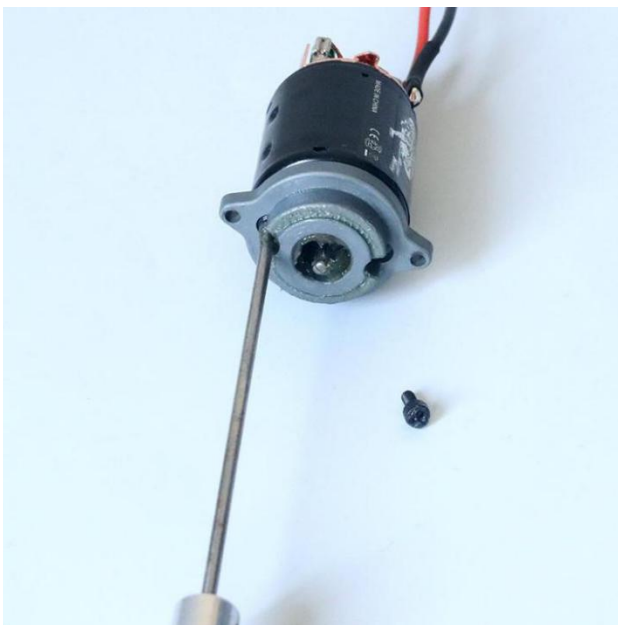
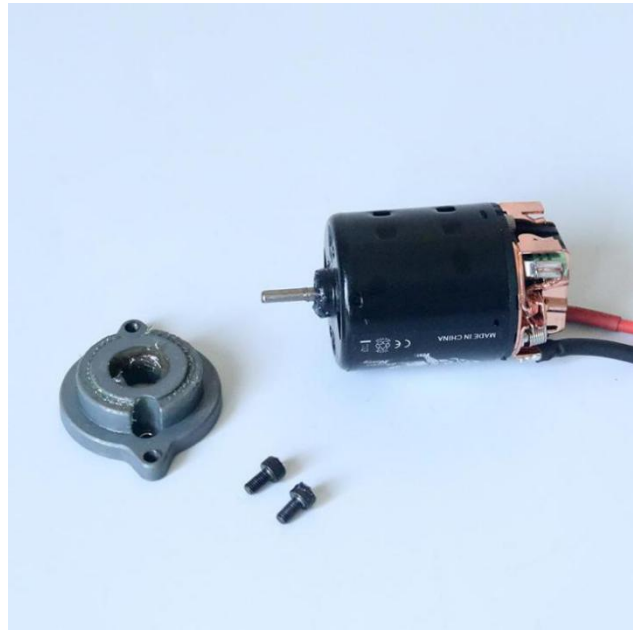
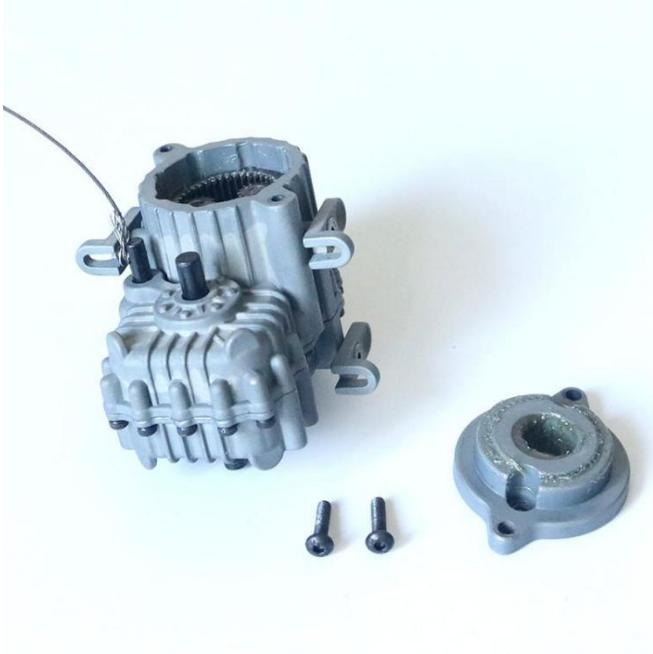

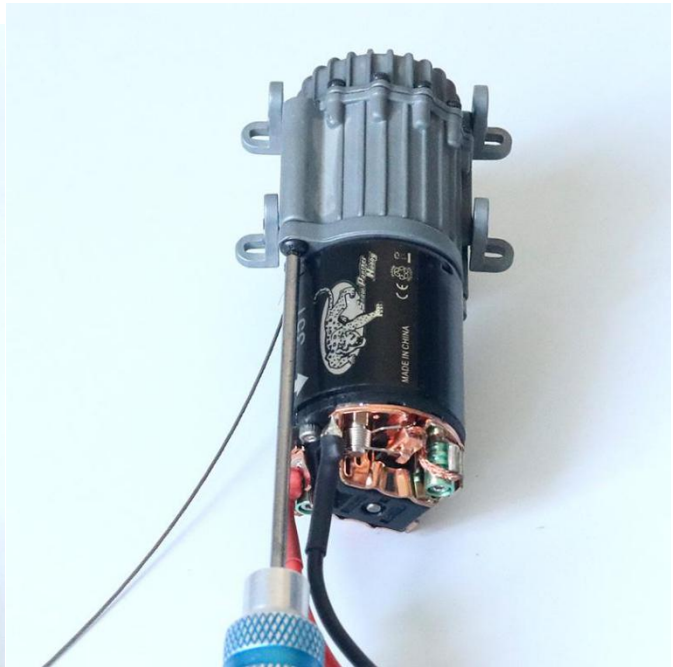
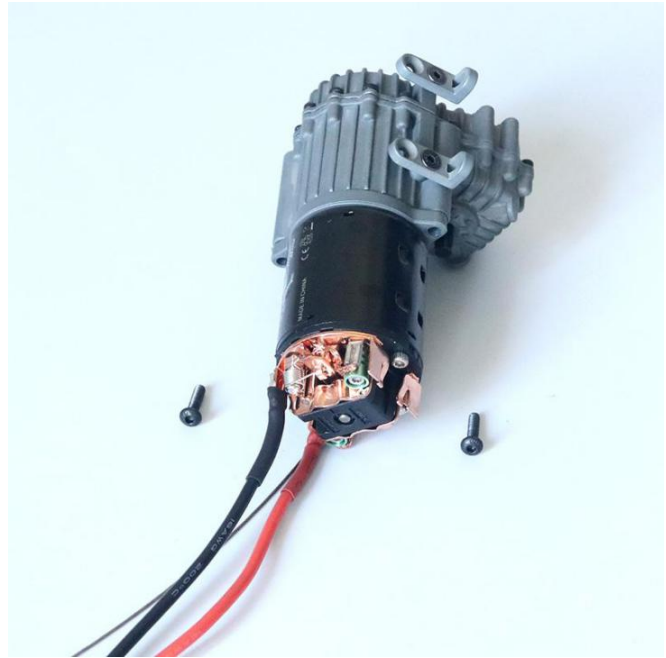
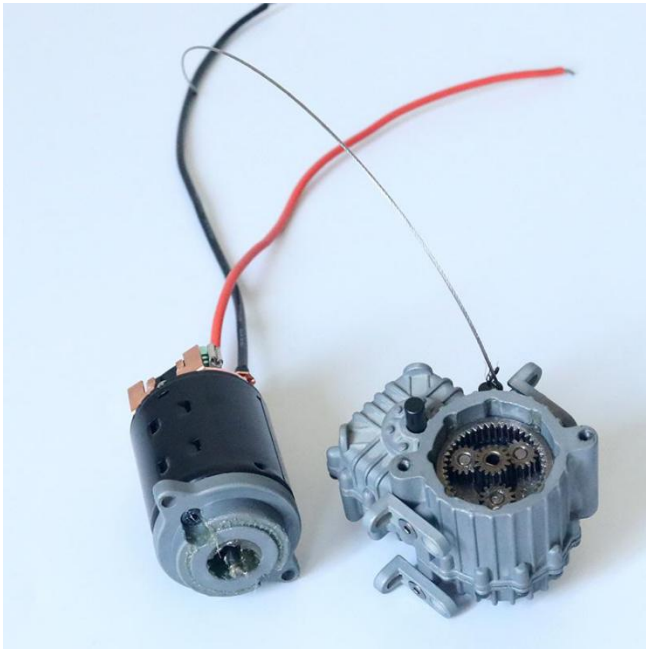

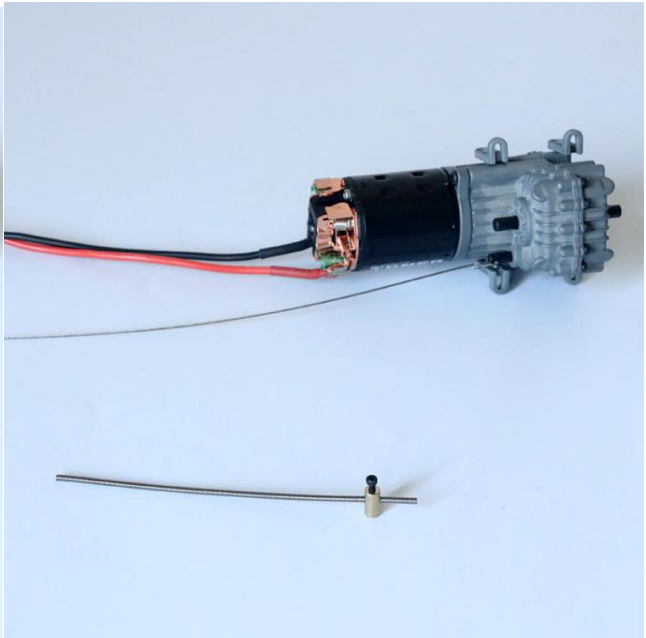
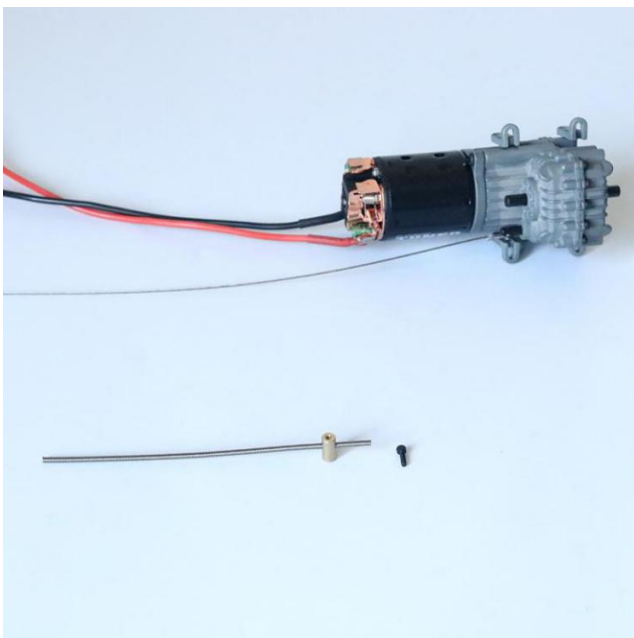
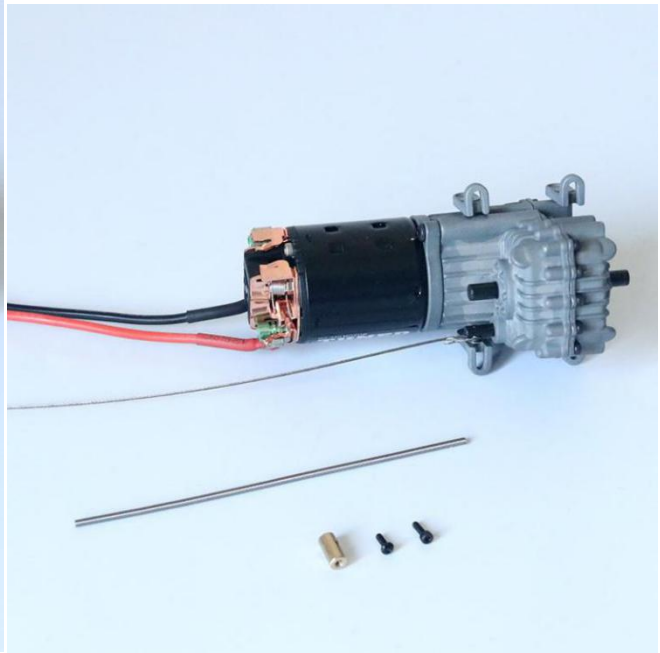
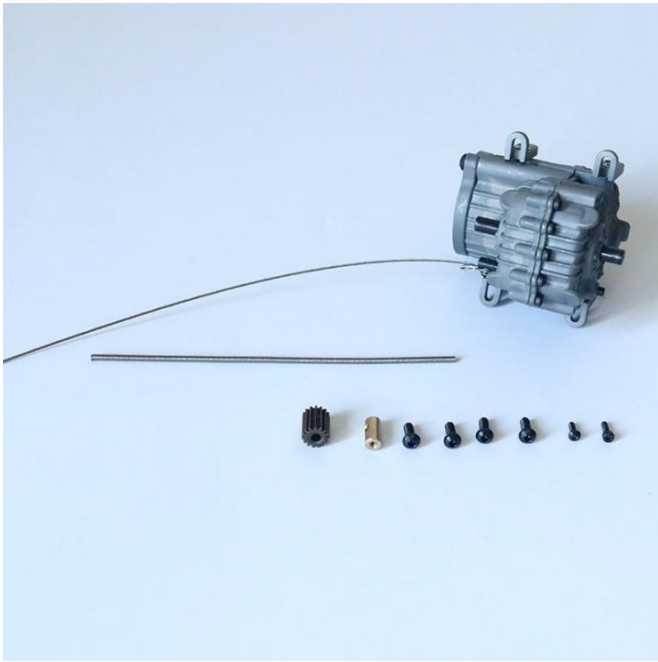

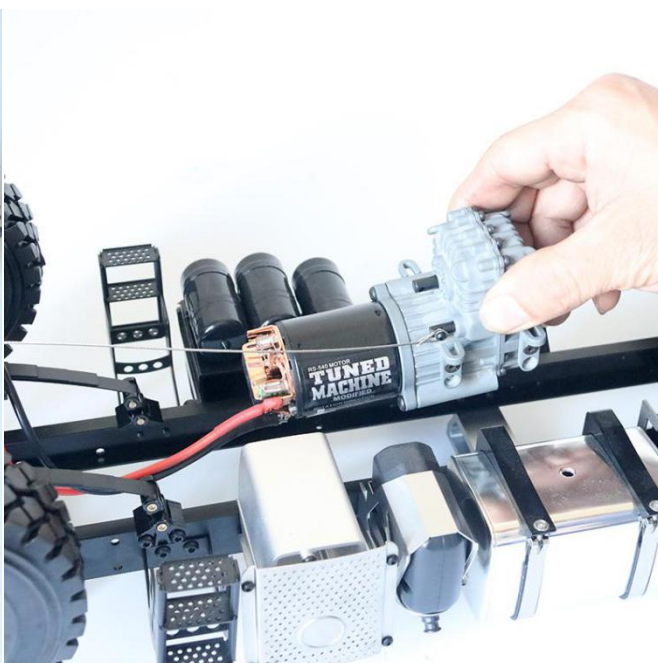
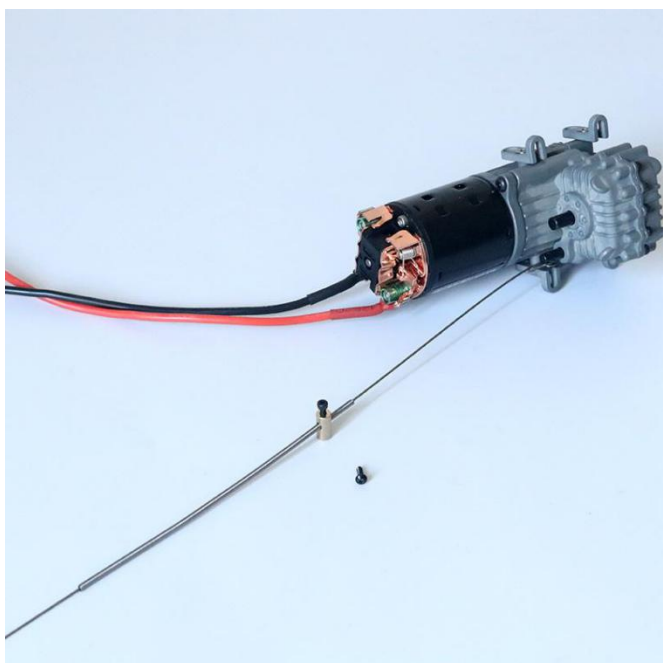

Put on the cable, fasten the cable screw with proper force, and ensure the sheath fastening passes through smoothly

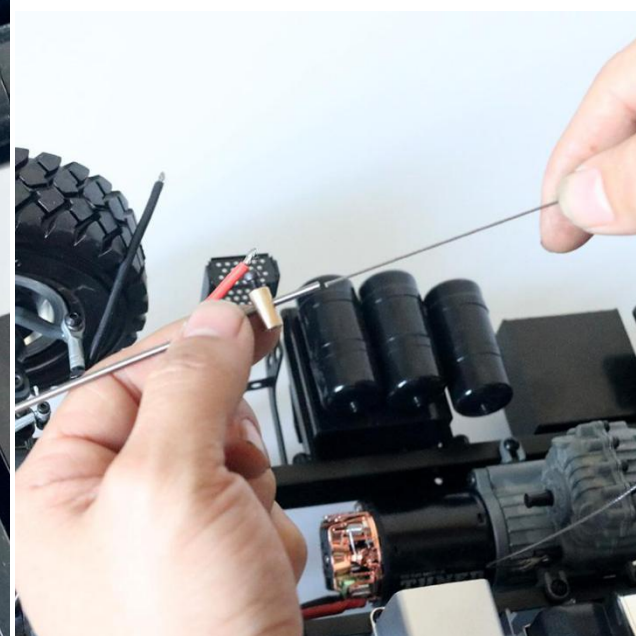
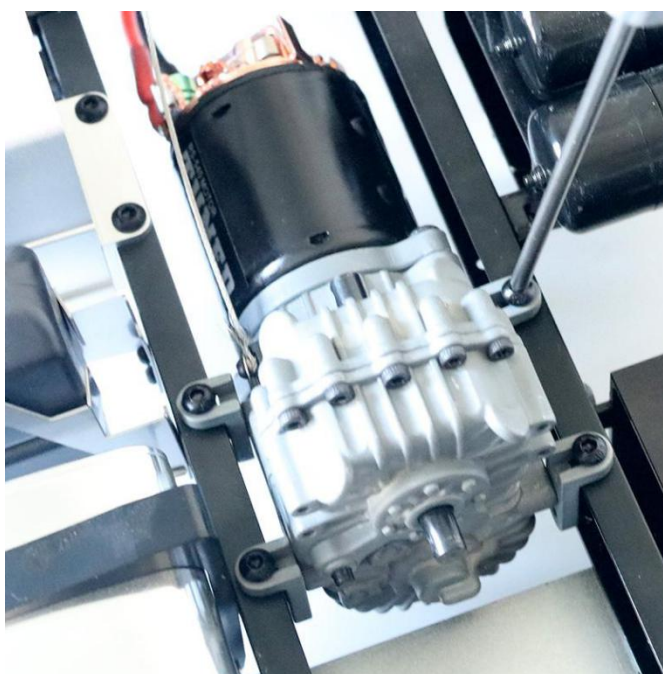

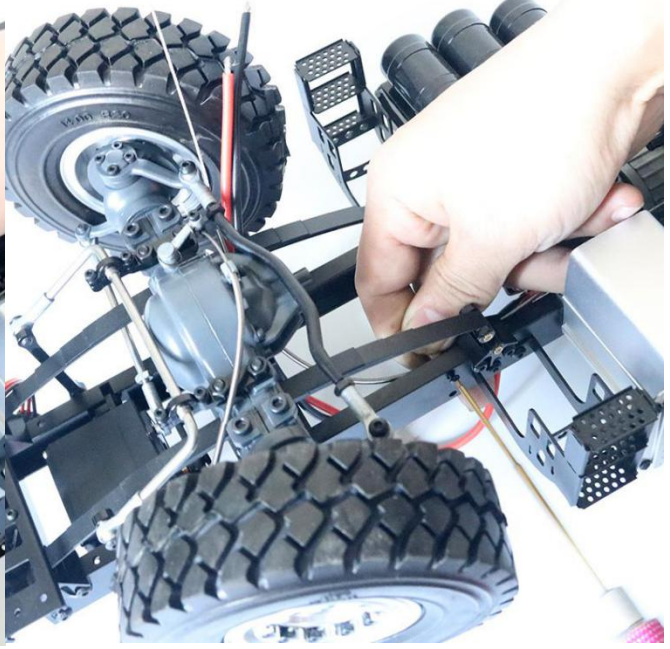
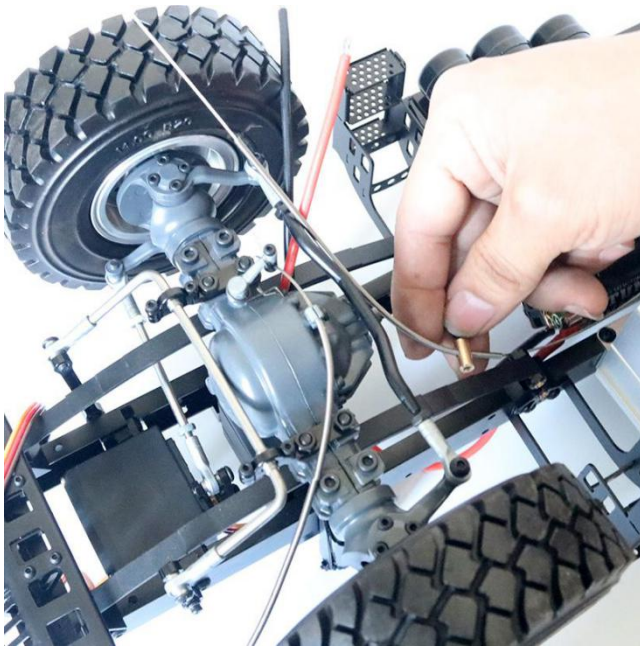

The cable passes through the cable seat

Installation diff locking, general assembly picture (mark for easy adjustment when finishing assembling)

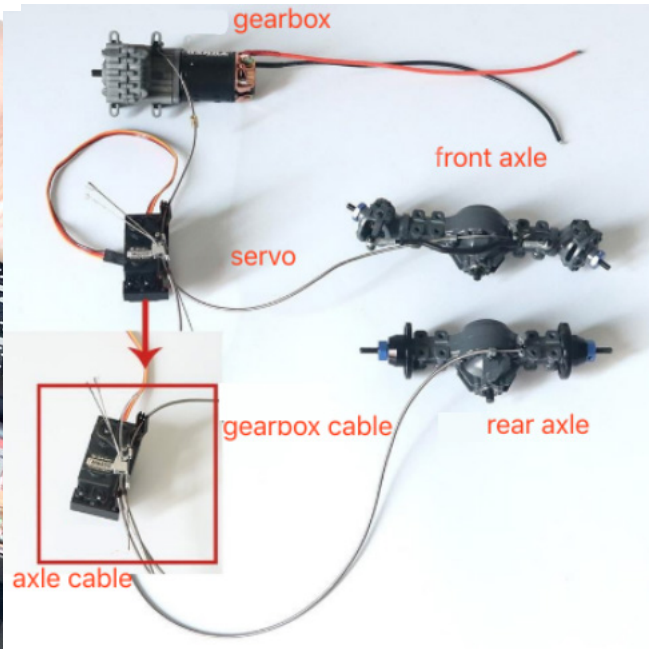
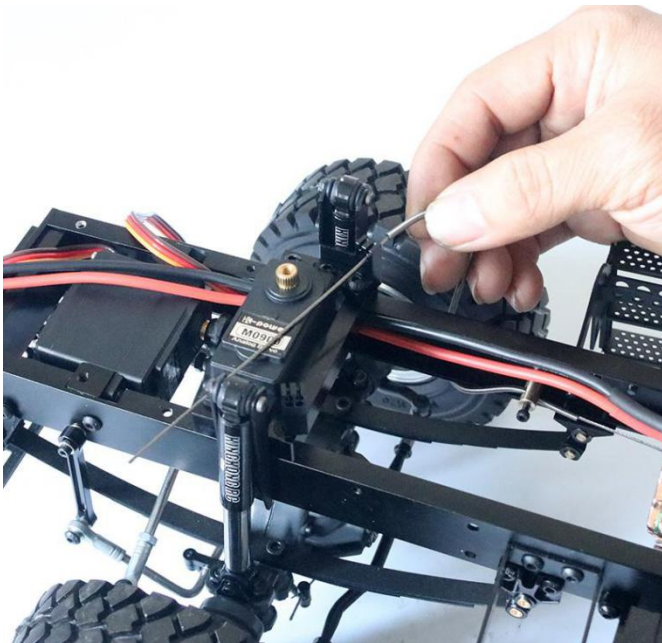

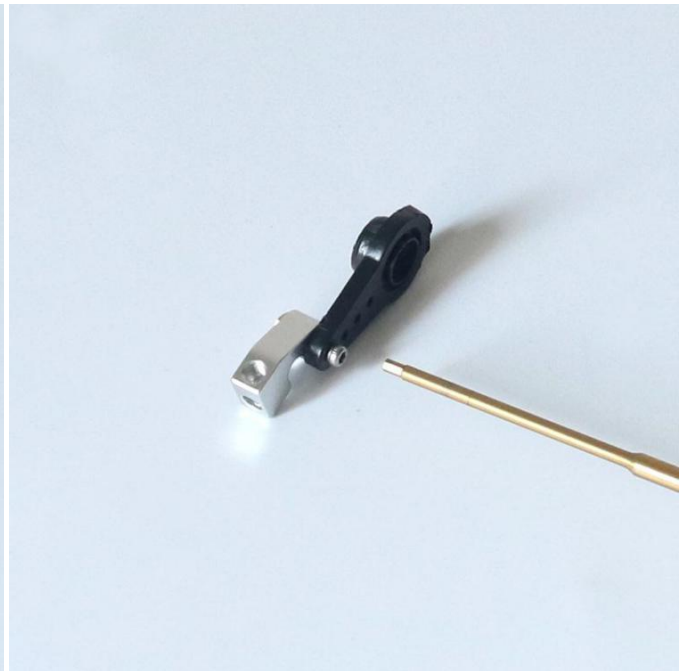

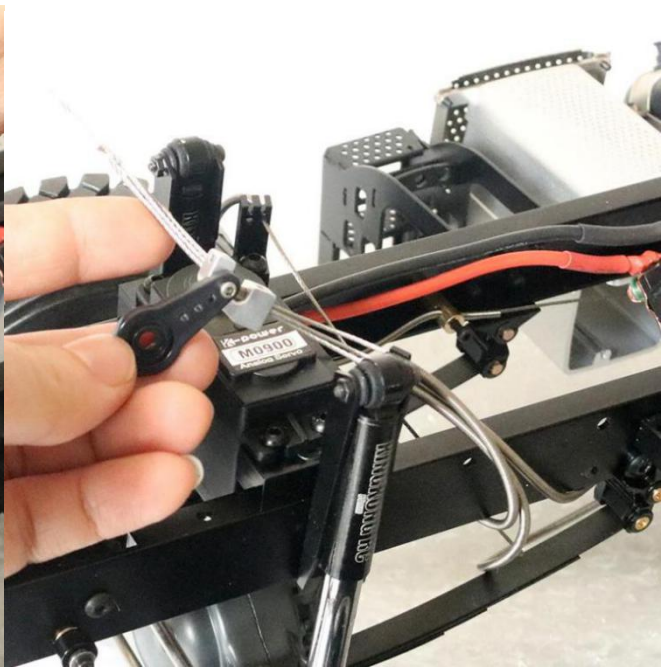
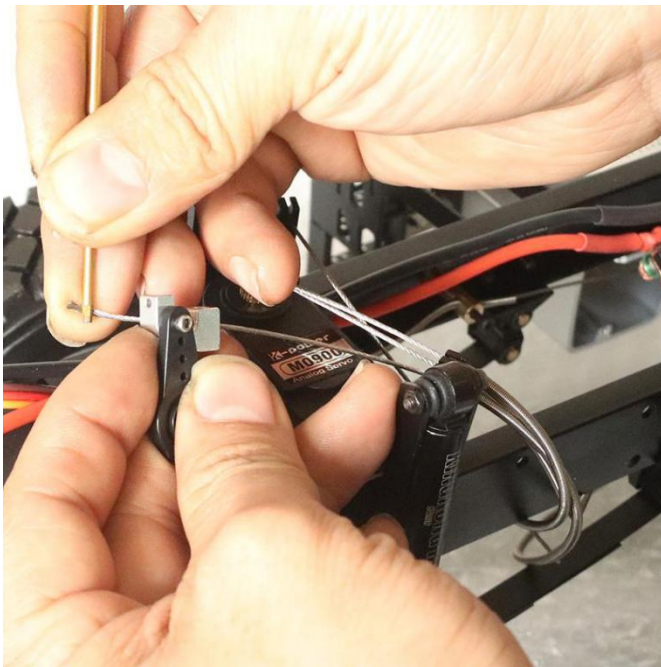
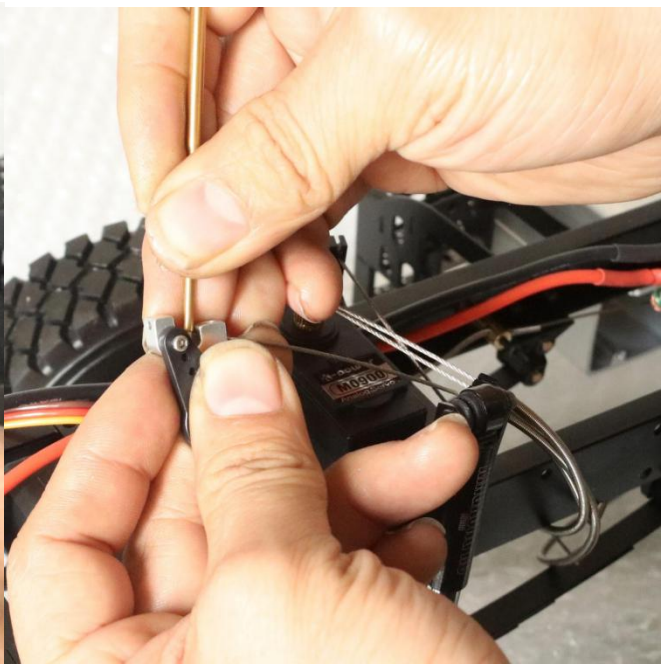

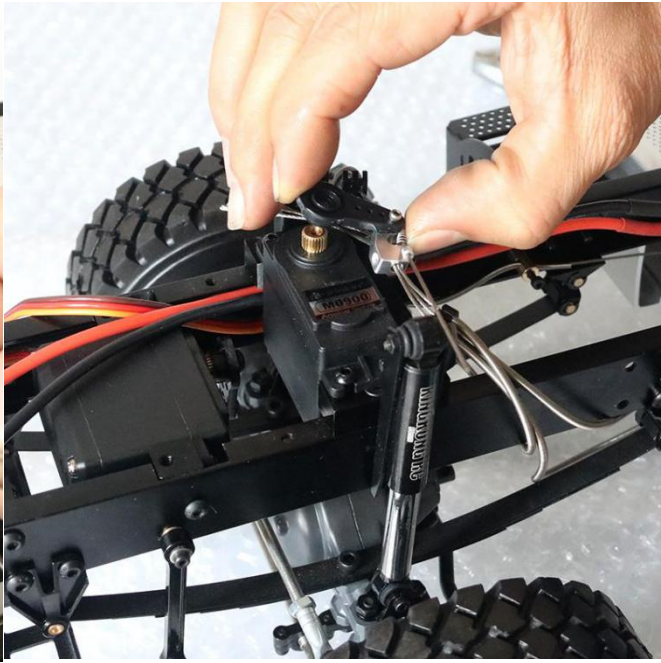
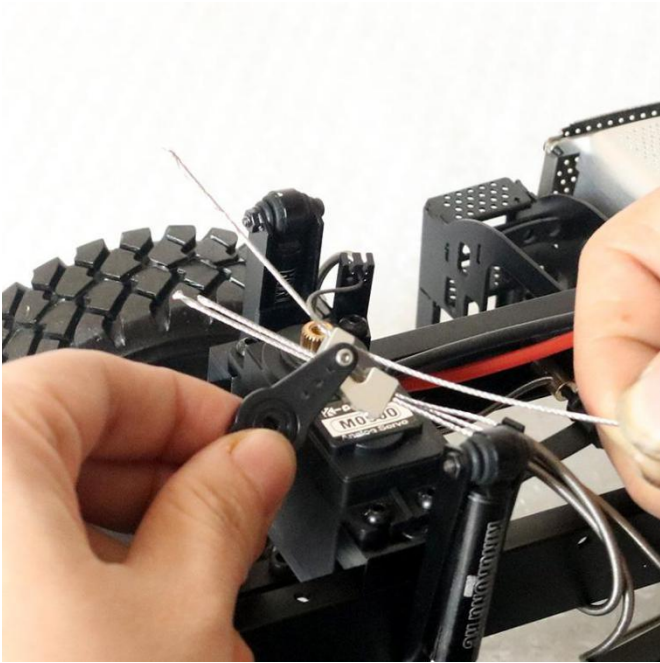
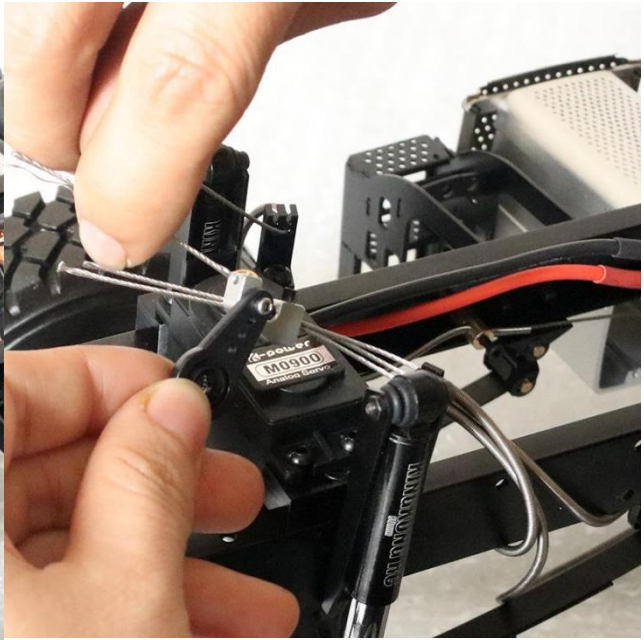
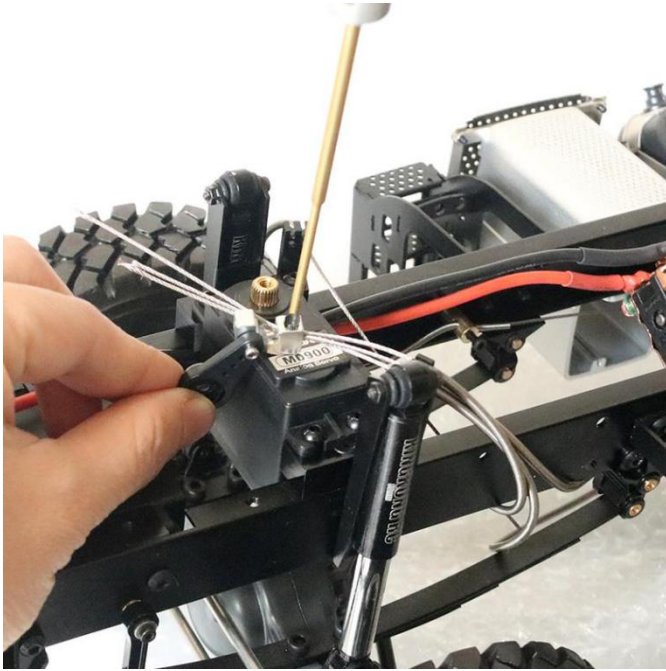

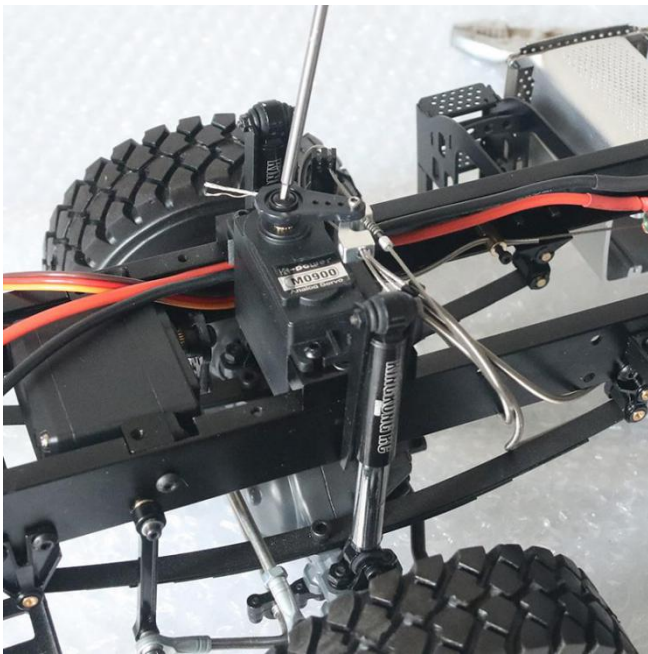
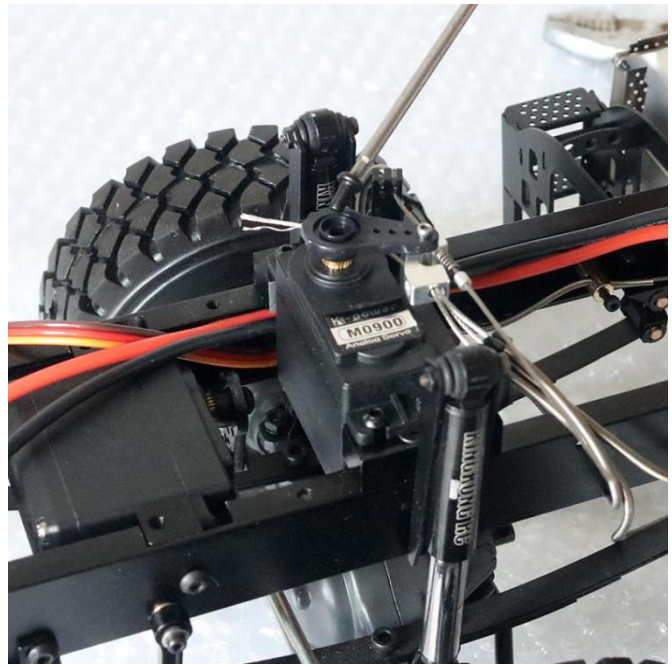
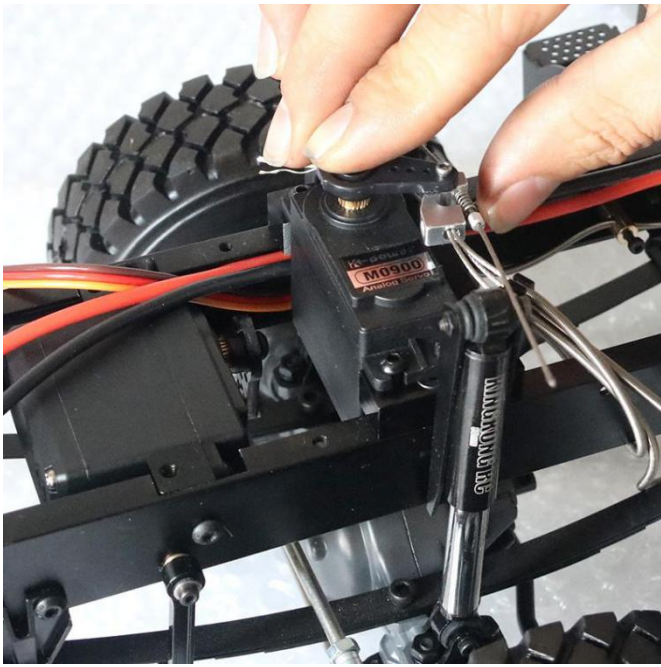

## Install the cab

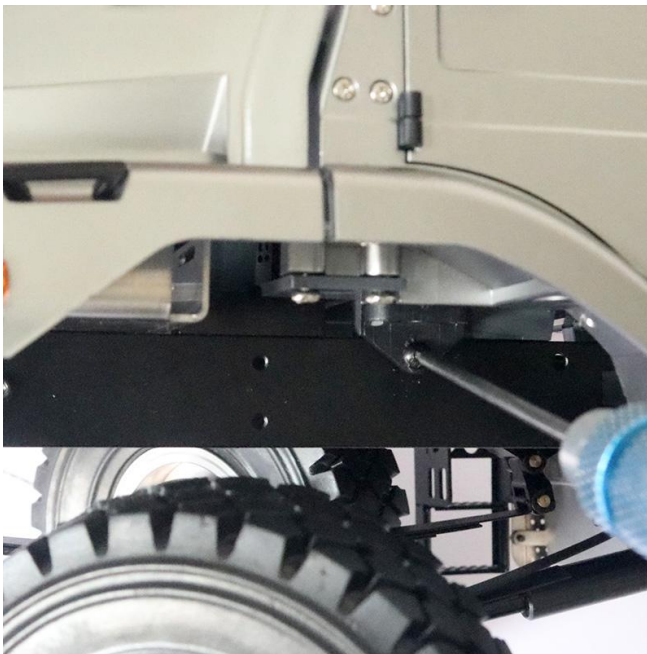
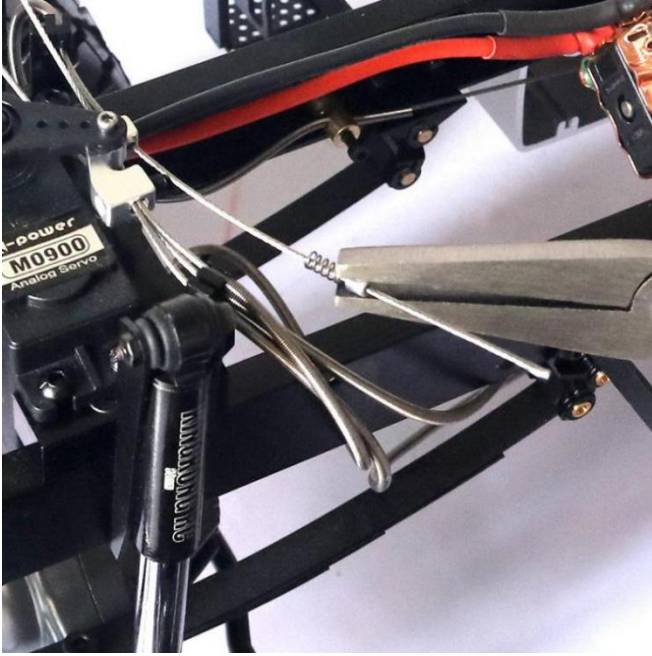

Install the hood



Install the front bumper

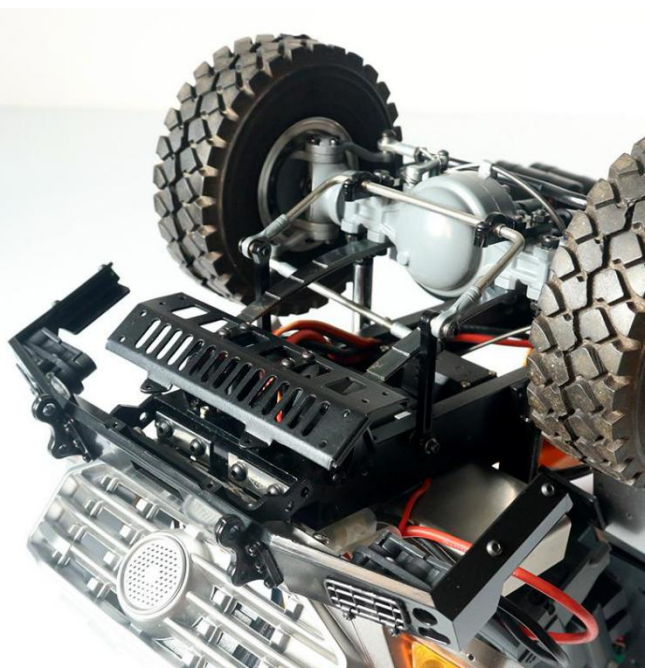

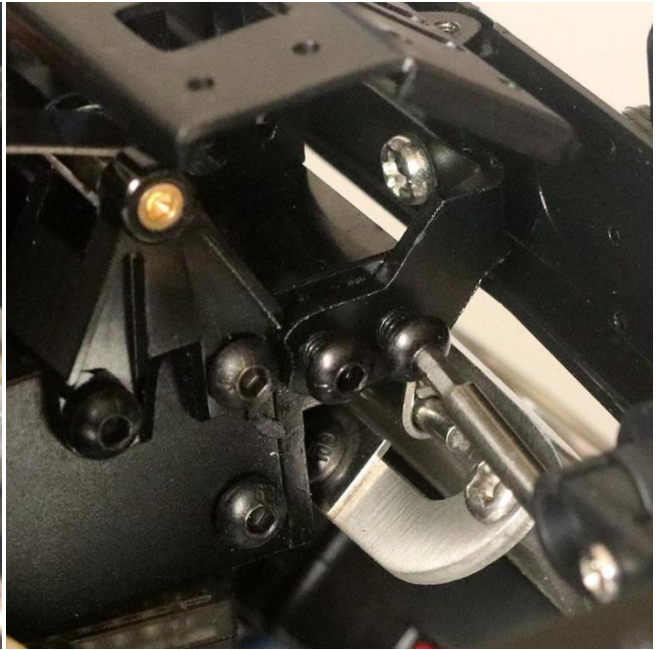
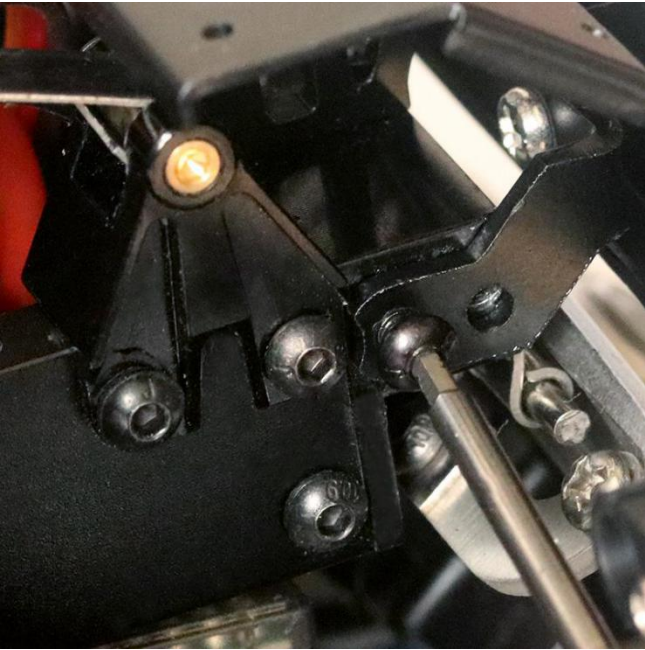
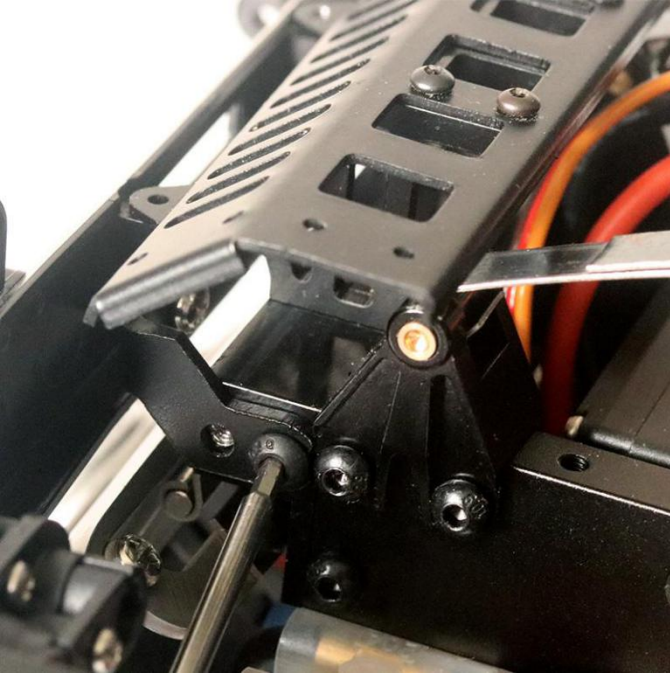

Install the wiper

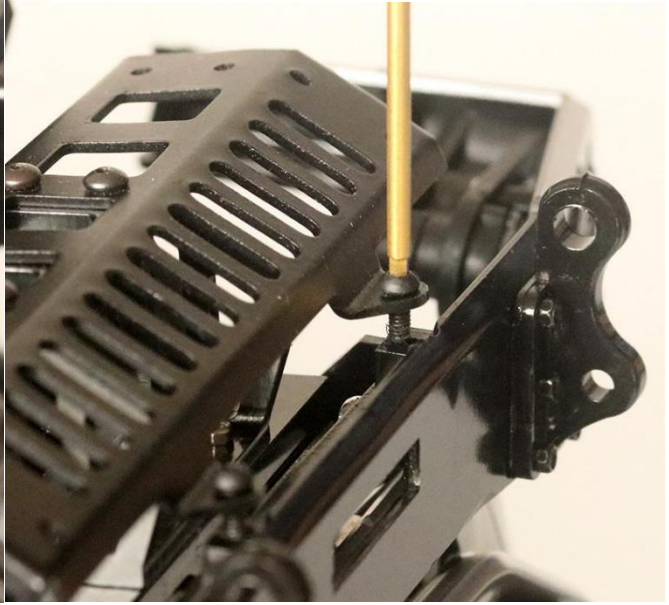

Install the antenna



Install the front grill and side grill



Install the snorkel cap



Install the right rear mirror

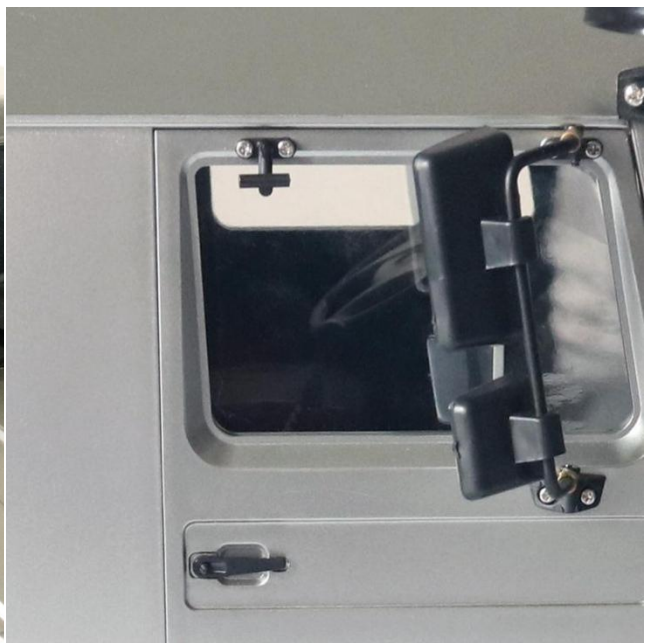

## Install the battery



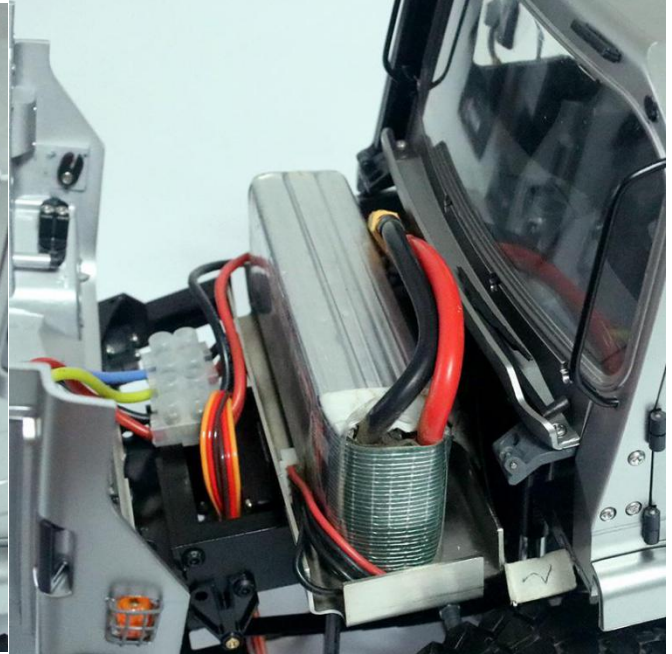
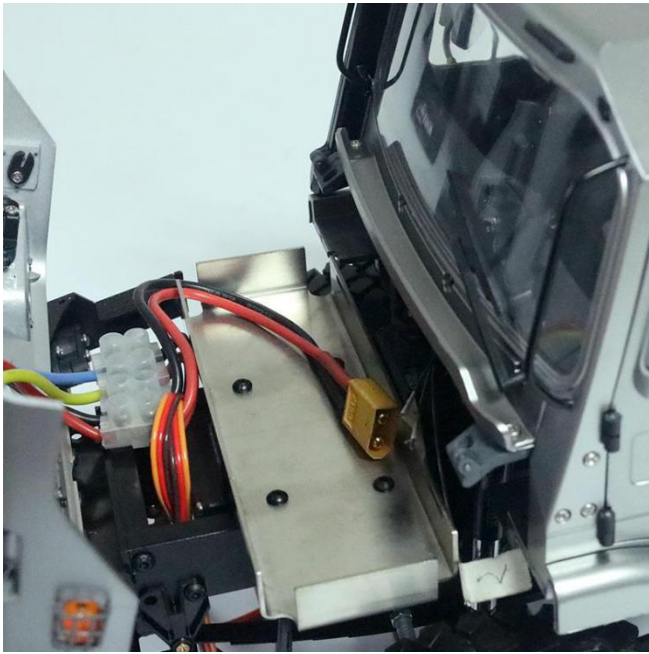

Open the door

